

HYDRAULIC EXCAVATOR

TAKEUCHI
From World First to World Leader

TB250-2



Product Features & Specifications

ENGINE

- U.S. EPA Final Tier 4 Compliant
- DOC+DPF Exhaust After Treatment
- Automatic Fuel Bleed System
- Dual Element Air Filter
- Automatic Idle
- Working Modes: Standard, Eco, and High Altitude
- Engine Preheat Starting Aid
- High Capacity Radiator and Hydraulic Oil Cooler
- High Capacity Fuel Filters

ELECTRICAL

- Multi-Informational Display (canopy)
- 5.7" Color Multi-Informational Display (cab)
- Sealed Rocker Switches
- 12 volt System with 55 amp Alternator
- LED: Two Forward Facing and One on the Right and Left Sides
- Travel Alarm
- Horn

TAKEUCHI FLEET MANAGEMENT

- 2 Year Standard Service
- Minimize Downtime
- Remote Diagnostics
- Utilization Tracking
- Proactive Maintenance
- Control Costs

UNDERCARRIAGE AND FRAME

- Triple Flanged Track Rollers
- 2-Speed Travel with Automatic Shift
- High Torque Planetary Final Drive
- Heavy Duty Dozer Blade with Float
- Large Wrap Around Counterweight
- 15.7" Rubber Tracks
- 15.7" Steel Tracks (optional)
- Power Angle Blade with Float and Bolt-on Cutting Edge (optional)

OPERATOR'S STATION

- ROPS / OPG Level 1 Four Post Canopy
- Deluxe High Back Suspension Seat
- Adjustable Arm Rests
- 12v Power Outlet
- 2" Retractable Seat Belt
- 3" Retractable Seat Belt (optional)
- Cab with Air Conditioner, Heat Defrost, Windshield Wiper and Washer, Skylight with Sunshade, AM / FM / MP3 / Bluetooth Radio (optional)

HYDRAULIC & WORKING EQUIPMENT

- Variable Displacement, Open Center Hydraulics
- Cushioned Boom, Arm, and Swing Cylinders
- Hydraulic Pilot Controls
- Proportional Auxiliary Controls with Detent
- Adjustable Auxiliary Flow
- Large Hydraulic Reservoir with Fluid Level Sight Gauge
- Primary Auxiliary Hydraulic Circuit Plumbed to Arm
- Multiple Attachment Presets
- Flow Selector Valve, Primary Auxiliary Circuit
- Pattern Change Valve (ISO or SAE)
- Boom Holding Valve with Lift Overload Alarm
- Pilot Accumulator
- Main Boom Cylinder Guard
- Long Arm with Integrated Thumb Mount
- Dual Pin Position Bucket (optional)
- Mechanical Bucket Quick Coupler (optional)
- Main Pin Hydraulic Thumb (optional)



Spacious Cabin



Automotive Styled Interior

TOUGH, POWERFUL, RELIABLE



Large Floor with Foot Rest



Wraparound Counterweight



Triple Flanged Track Rollers



Work Lights

With a proven pedigree and design philosophy, the TB250-2 delivers excellent performance and durability in a 5t excavator. The TB250-2's feature set allows it to perform a wide range of tasks. Standard long arm enables the TB250-2 to have a dig depth of over 12 ft 4 in and a max reach of 20 ft 1 in. The primary auxiliary circuit delivers over 24 gpm, has a detent mode for continuous flow attachments, and a proportional thumb wheel provides precise control increasing attachment versatility and functionality. Hydraulic flow rates are adjusted from the comfort of the cabin and allow for

multiple attachment presets. The cabin is spacious and features a deluxe high back suspension seat with adjustments for height, weight, fore and aft position, and tilt. Controls are intuitive and include a multi-function monitor, rocker switches for various machine functions, dial type throttle, and low effort pilot joysticks. All steel construction and a wraparound counterweight provide excellent protection and durability, and overhead opening service hoods enhance and simplify access to key daily inspection points.



Large lockable service hoods provide vandalism protection and outstanding maintenance access.

OPERATING PERFORMANCE

Operating Weight - Canopy	10,957 lb	(4,970 kg)
Cab	11,288 lb	(5,120 kg)
Maximum Bucket Breakout Force	10,430 lb	(4,731 kg)
Maximum Arm Digging Force	5,261 lb	(2,386 kg)
Arm Length	5 ft 9.2 in	(1,760 mm)
Slew Speed	9.5 rpm	
Traction Force	12,320 lb	(5,588 kg)
Ground Pressure - Canopy	4.2 psi	(29.0 kPa)
Cab	4.4 psi	(30.0 kPa)
Max Travel Speed		
Low Range	1.7 mph	(2.8 km / hr)
High Range	3.2 mph	(5.2 km / hr)

HYDRAULIC SYSTEM

Total Hydraulic Flow	40.9 gpm	(155.3 Lpm)
Auxiliary Flow - Primary Circuit	24.2 gpm	(91.7 Lpm)
Hydraulic System Pressure	3,481 psi	(24.0 MPa)

ENGINE

Make / Model	Yanmar / 4TNV88C-PTB
Displacement	133.6 cu in (2.2 L)
Horsepower @ 2,400 rpm	39.0 hp (29.1 kW)
Maximum Torque @ 1,440 rpm	106.9 ft-lb (144.9 Nm)

FLUID CAPACITIES

Engine Lubrication	7.8 qt	(7.4 L)
Cooling System	7.4 qt	(7.0 L)
Fuel Tank Capacity	18.5 gal	(70.0 L)
Fuel Consumption (65% of Full Load)	gal / hr	(L / hr)
Hydraulic Reservoir Capacity	11.9 gal	(45.0 L)
Hydraulic System Capacity	25.1 gal	(95.0 L)



Canopy Display



Cab Display





Long Arm with Thumb Mount



Multi-Function Switch Bank

TB250-2 Lifting Capacities at Ground Level*

Lift Point Radius from Rotation Axis	9 ft (2,743 mm)	12 ft (3,657 mm)
 Lifting Capacities Over Front, Blade Down	5,611 lb (2,545 kg)	3,661 lb (1,638 kg)
 Lifting Capacities Over Side	2,517 lb (1,142 kg)	1,683 lb (763 kg)

* Ratings based on ISO10567 and do not exceed 87% of hydraulic lift or 75% of tipping load.

ATTACHMENTS

Takeuchi now offers attachments for all of your Takeuchi equipment. See your authorized Takeuchi dealer for additional information and attachment options.

TB250-2 Compact Excavator

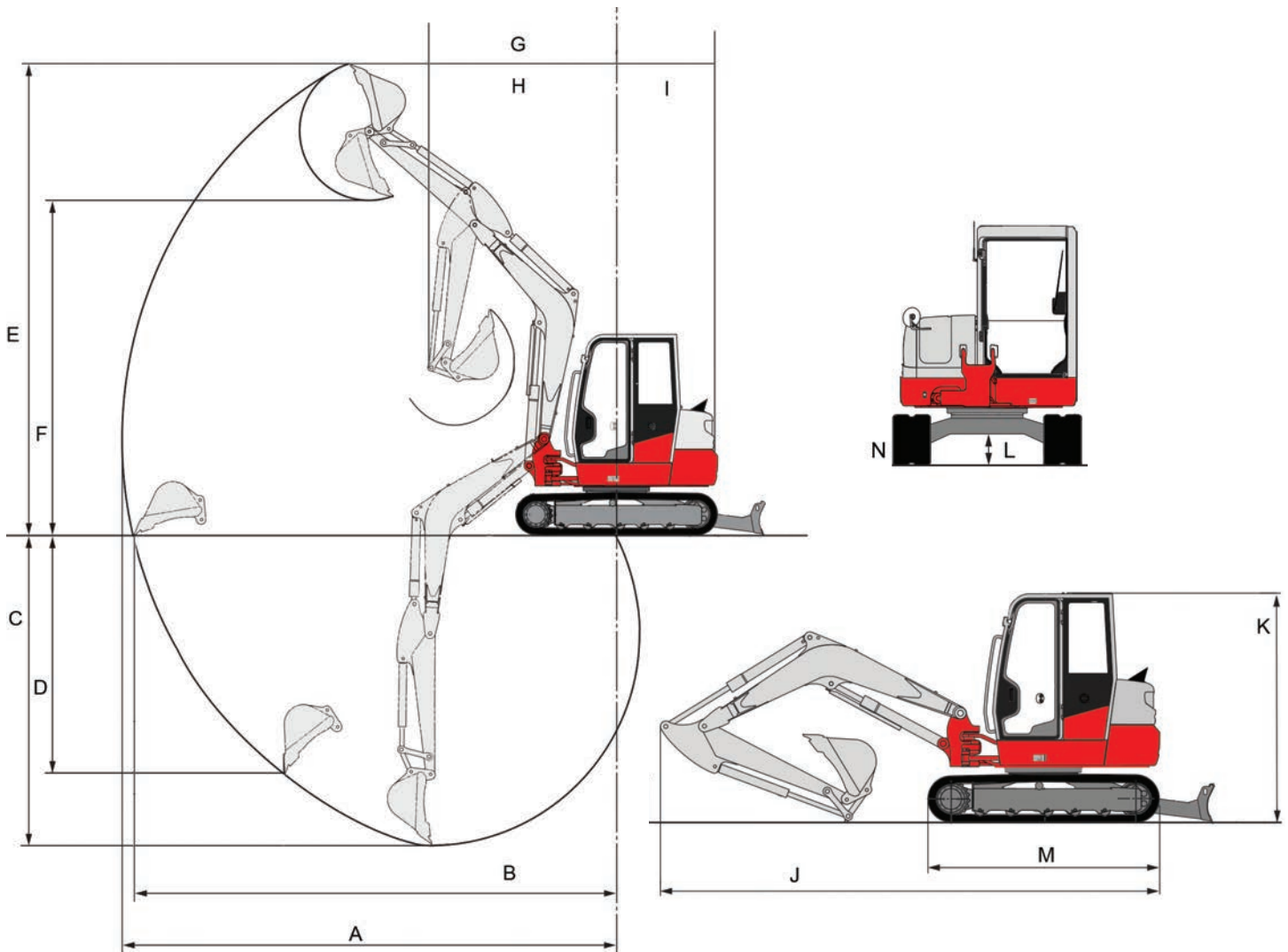

MACHINE DIMENSIONS

A	Maximum Reach	20 ft 1.0 in	(6,120 mm)
B	Maximum Reach at Ground Level	19 ft 7.6 in	(5,985 mm)
C	Maximum Digging Depth	12 ft 4.8 in	(3,780 mm)
D	Maximum Vertical Digging Depth	9 ft 9.5 in	(2,985 mm)
E	Maximum Dig Height	18 ft 6.6 in	(5,655 mm)
F	Maximum Dumping Height	13 ft 3.3 in	(4,045 mm)
G	Front Swing Radius	7 ft 7.7 in	(2,330 mm)
H	Front Swing Radius with Boom Offset	6 ft 0.8 in	(1,850 mm)
I	Tail Swing (Slew) Radius	4 ft 5.5 in	(1,360 mm)
J	Transport Length	18 ft 0.3 in	(5,495 mm)
K	Transport Height	8 ft 5.2 in	(2,570 mm)
L	Ground Clearance	13.2 in	(335 mm)
M	Undercarriage Length	8 ft 2.4 in	(2,500 mm)
N	Track Width (Rubber)	15.7 in	(400 mm)
O	Undercarriage Width	6 ft 0.0 in	(1,839 mm)



2 YEAR
2,000 HOUR
FULL MACHINE
WARRANTY



© 2019 Takeuchi Manufacturing (U.S.), Ltd. All Rights Reserved. Printed in the U.S.A.
In accordance with our established policy of continued improvement, specifications and features are subject to change without notice. Pictures may show options other than standard equipment.
FORM: TB250-2 Compact Excavator Spec Sheet - Oct. 2019

TAKEUCHI
From World First to World Leader