

HYDRAULIC EXCAVATOR

**TAKEUCHI**

*From World First to World Leader*

# TB290



# Product Features & Specifications

## ENGINE

- U.S. EPA Final Tier 4 Compliant
- Turbocharged
- DOC+DPF Exhaust After Treatment
- Automatic Fuel Bleed System
- Dual Element Air Filter
- Automatic Idle
- Working Modes: Power, Eco, and High Altitude
- Engine Preheat Starting Aid
- High Capacity Radiator and Hydraulic Oil Cooler
- High Capacity Fuel Filters

## ELECTRICAL

- 5.7" Color Multi-Informational Display
- Sealed Rocker Switches
- 12 volt System with 80 amp Alternator
- Halogen Work Lights: Boom and Side Cover
- Travel Alarm
- Horn

## TAKEUCHI FLEET MANAGEMENT

- 2 Year Standard Service
- Minimize Downtime
- Remote Diagnostics
- Utilization Tracking
- Proactive Maintenance
- Control Costs

## UNDERCARRIAGE AND FRAME

- Triple Flanged Track Rollers
- 2-Speed Travel with Automatic Shift
- High Torque Planetary Final Drive
- Auto Track Tensioning
- Heavy Duty Dozer Blade with Float
- Large Wraparound Counterweight
- 17.7" Rubber Tracks
- 17.7" Segmented Rubber Tracks (optional)
- 21.7" Steel Tracks (optional)
- Power Angle Blade with Float (optional)

## OPERATOR'S STATION

- Cab with Automatic Climate Control System, Windshield Wiper and Washer, Skylight with Sunshade, AM / FM / MP3 Radio, 12v Power Outlet
- ROPS and OPG level 1
- Deluxe High Back Suspension Seat
- Adjustable Arm Rests
- 2" Retractable Seat Belt
- 3" Retractable Seat Belt (optional)

## HYDRAULIC & WORKING EQUIPMENT

- Closed Center, Load Sensing Hydraulics
- Cushioned Boom, Arm, and Swing Cylinders
- Load Sensing Piston Pump
- Hydraulic Pilot Controls
- Proportional Auxiliary Controls with Detent
- Adjustable Auxiliary Flow
- Large Hydraulic Reservoir with Fluid Level Sight Gauge
- Primary and Secondary Auxiliary Hydraulic Circuit Plumbed to Arm
- Multiple Attachment Presets
- Flow Selector Valve, Primary Auxiliary Circuit
- Pilot Accumulator
- Pattern Change Valve (ISO or SAE)
- Dual Boom Cylinders
- Boom Holding Valve with Lift Overload Alarm
- Long Arm with Integrated Thumb Mount
- Dual Pin Position Bucket (optional)
- Mechanical Bucket Quick Coupler (optional)
- Main Pin Hydraulic Thumb (optional)



Spacious Cabin



Automotive Styled Interior

# TOUGH, POWERFUL, RELIABLE



Large Floor with Foot Rest



Wraparound Counterweight



Triple Flange Track Rollers



Work Lights

Big on performance, the TB290 has a wide array of features that maximize efficiency and productivity. A closed center, load sensing hydraulic system allows the TB290 to have outstanding multi-function capabilities, and the attachment presets greatly expands the machine's versatility. The cabin on the TB290 is spacious and well-appointed. A large color monitor keeps the operator informed of critical machine functions. The auxiliary flow rates can be adjusted from the operator's seat. A deluxe high back suspension seat can be adjusted for comfort, and the

automatic climate control system keeps the operator comfortable year-round. Service and maintenance access is greatly enhanced with an engine and side cover that open high overhead for unmatched ground-level serviceability. Key hydraulic components including the main control valve, hydraulic tank and sight gauge, and selector valve are mounted outboard for easier inspection and maintenance, and all daily inspection points for the engine can be easily accessed from the rear of the machine.



Large lockable service hoods provide vandalism protection and outstanding maintenance access.

## OPERATING PERFORMANCE

Operating Weight - Cab (Rubber)	18,630 lb	(8,450 kg)
Cab (Steel)	19,145 lb	(8,685 kg)
Maximum Bucket Breakout Force	16,565 lb	(7,514 kg)
Maximum Arm Digging Force	8,161 lb	(3,702 kg)
Arm Length	7 ft 0.0 in	(2,130 mm)
Slew Speed	10.3 rpm	
Traction Force	19,780 lb	(8,972 kg)
Ground Pressure - Cab (Rubber)	5.5 psi	(37.9 kPa)
Cab (Steel)	4.8 psi	(33.1 kPa)
Max Travel Speed		
Low Range	1.6 mph	(2.6 km / hr)
High Range	3.1 mph	(5.0 km / hr)

## ENGINE

Make / Model	Yanmar / 4TNV98CT	
Displacement	202 cu in	(3.3 L)
Horsepower @ 2,000 rpm	69.2 hp	(51.6 kW)
Maximum Torque @ 1,300 rpm	227.2 ft-lb	(308 Nm)

## FLUID CAPACITIES

Engine Lubrication	10.8 qt	(10.2 L)
Cooling System	14.8 qt	(14.0 L)
Fuel Tank Capacity	33.8 gal	(128.0 L)
Fuel Consumption (65% of Full Load)	2.4 gal / hr	(9.1 L / hr)
Hydraulic Reservoir Capacity	19.3 gal	(73.0 L)
Hydraulic System Capacity	37.0 gal	(140.0 L)

## HYDRAULIC SYSTEM

Total Hydraulic Flow	62.5 gpm	(236.6 Lpm)
Auxiliary Flow - Primary Circuit	26.4 gpm	(100.0 Lpm)
Auxiliary Flow - Secondary Circuit	14.5 gpm	(55.0 Lpm)
Hydraulic System Pressure	3,990 psi	(27.5 MPa)



Multi-Informational Display



Dozer Blade with Float





Long Arm with Thumb Mount



Multi-Function Switch Bank

## TB290 Lifting Capacities at Ground Level\*

Lift Point Radius from Rotation Axis	9 ft (2,743 mm)		12 ft (3,657 mm)	
 Lifting Capacities Over Front, Blade Down	6,728 lb	(3,052 kg)	8,524 lb	(3,866 kg)
 Lifting Capacities Over Side	5,829 lb	(2,644 kg)	3,839 lb	(1,741 kg)

\* Ratings based on ISO10567 and do not exceed 87% of hydraulic lift or 75% of tipping load.

## ATTACHMENTS

Takeuchi now offers attachments for all of your Takeuchi equipment. See your authorized Takeuchi dealer for additional information and attachment options.

# TB290 Compact Excavator

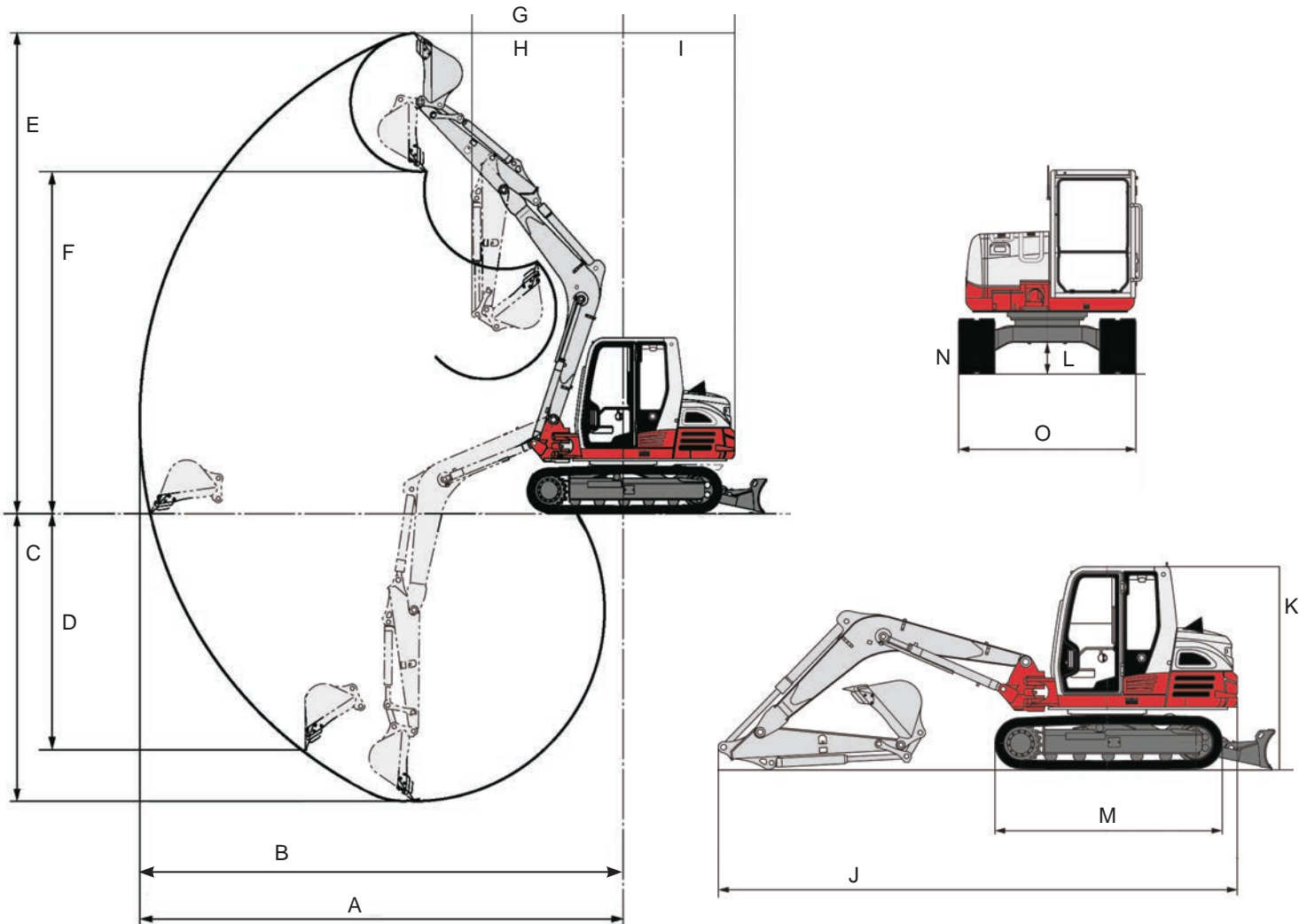

## MACHINE DIMENSIONS

A	Maximum Reach	24 ft 5.0 in	(7,435 mm)
B	Maximum Reach at Ground Level	23 ft 11.0 in	(7,290 mm)
C	Maximum Digging Depth	15 ft 0.0 in	(4,580 mm)
D	Maximum Vertical Digging Depth	12 ft 6.4 in	(3,820 mm)
E	Maximum Dig Height	23 ft 11.1 in	(7,290 mm)
F	Maximum Dumping Height	17 ft 3.0 in	(5,258 mm)
G	Front Swing Radius	8 ft 2.0 in	(2,495 mm)
H	Front Swing Radius with Boom Offset	6 ft 8.0 in	(2,030 mm)
I	Tail Swing Radius	5 ft 5.0 in	(1,650 mm)
J	Transport Length	21 ft 10.0 in	(6,660 mm)
K	Transport Height	8 ft 5.0 in	(2,565 mm)
L	Ground Clearance	1 ft 3.0 in	(385 mm)
M	Undercarriage Length	9 ft 4.0 in	(2,855 mm)
N	Track Width (Rubber)	17.7 in	(450 mm)
O	Undercarriage Width	7 ft 3.0 in	(2,210 mm)



**2 YEAR**  
**2,000 HOUR**  
**FULL MACHINE**  
**WARRANTY**



© 2019 Takeuchi Manufacturing (U.S.), Ltd. All Rights Reserved. Printed in the U.S.A.  
In accordance with our established policy of continued improvement, specifications and features are subject to change without notice. Pictures may show options other than standard equipment.  
FORM: TB290 Compact Excavator Spec Sheet - Feb. 2019 - (TFM) s/n 185102670 ~

**TAKEUCHI**  
From World First to World Leader