



# CP75 II

COMMERCIAL CLASS PAVER



## CP75 II

Engine	74hp (55kW) Deutz® Tier IVf
EZC815 Width	8'-15' (2.43-4.59m)
Screed Heat	Electric Elements
Weight	17,000lbs (7711kg)



# OVERVIEW

**The CP75 II is setting new standards in commercial paving.** Bringing together state of the art technology with tried-and-true components and design, the CP75 II is built around the simple concept of enhancing paving performance for commercial contractors. Whether that is the industry's leading conveyor system for efficiency and anti-mix segregation or renowned 8'-15' (2.43-4.59m) electrically heated screed, Carlson's mid-sized commercial paver offers contractors unparalleled performance and mat quality in an economical platform.

A machine designed to meet the challenges of a wide array of applications, the CP75 II excels on jobsites ranging from driveways to large parking lots. Its compact and low design allows it to pave in size restrictive areas, including parking garages or covered areas, while its low hood and screed mounted controls give optimal visibility and comfort for crew performance.

## Performance & Exceptional Mat Quality In An Economical Paver Platform





# CP75



**Unmatched Performance** with its powerful, high torque 74hp Deutz® Tier IV Final engine (No DEF), one piece heavy-duty frame, innovative High Flow Material Conveyor™ or traditional chain/slat conveyors, and its rebuildable, long lasting platform.

**Unequaled Contractor Focus** with its low hood for optimal visibility, screed mounted controls that keep them relative to the operator at all times, intuitive switch placement, and the most standard crew comfort features in its class.

**Unparalleled Mat Quality** with its renowned EZC815 electrically heated screed, engineered and built with over 30 years of award winning highway-class know-how and performance.



# FEATURES & BENEFITS

Designed and built around the operator and performance, the CP75 II couples high strength components, a fully rebuildable platform and ergonomic controls for a reliable, longer lasting paver platform.

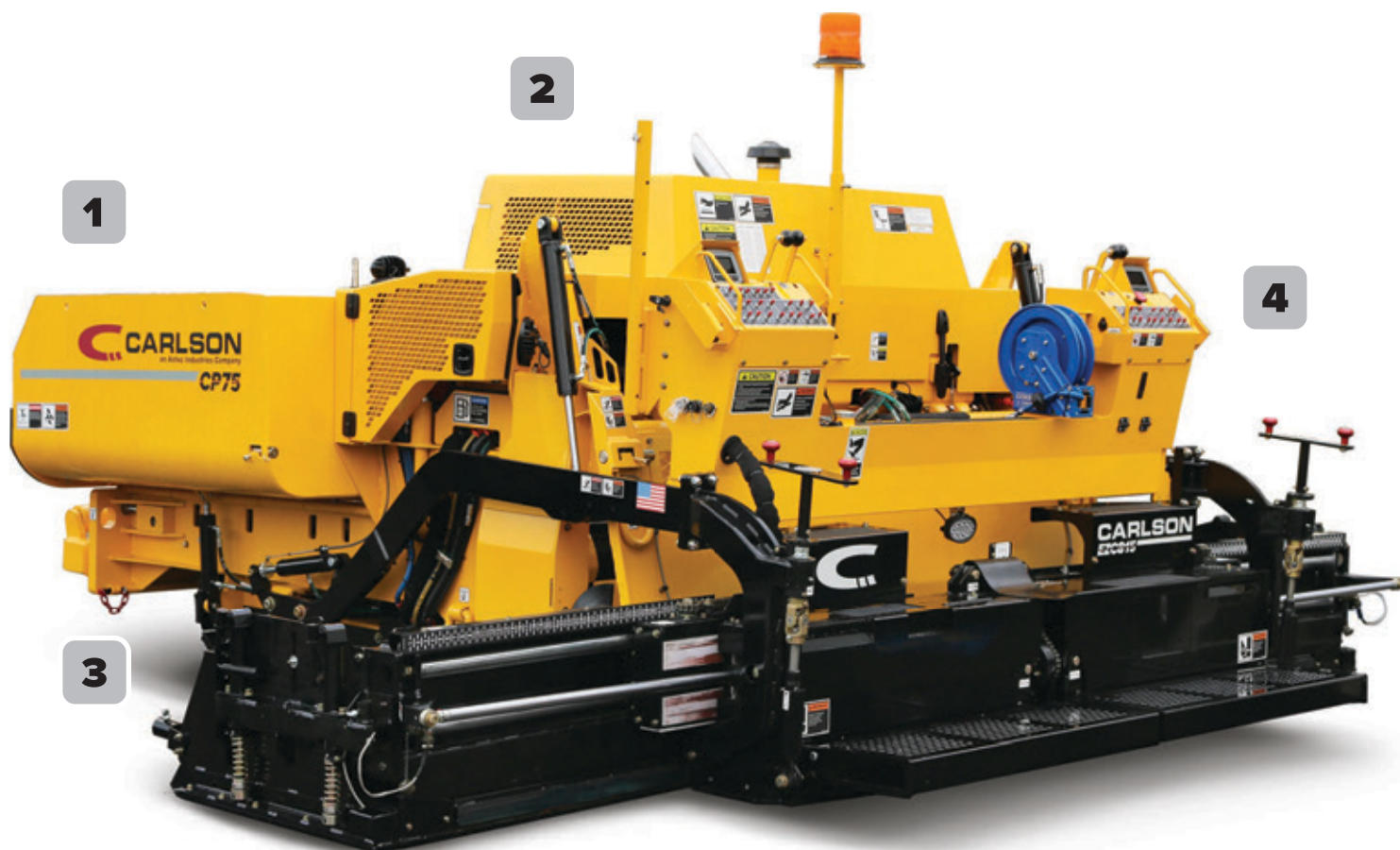

## 1 Heavy-Duty Steel Frame

The CP75 II's chassis is a one piece, cold-rolled steel frame giving the platform a heavy-duty foundation, providing longer lifecycle and greater structural support than any paver in its class. And because all components on the platform are bolted to the frame, contractors are able to rebuild their machine around the frame for longer service life and maximization of return on investment.

## 2 Tier IV Final Engine

The highly efficient and powerful 74hp Deutz® 2.9 L4 Tier IV Final turbocharged engine (No DEF) provides contractors with exceptional amounts of torque and responsive power. Producing a leading 192 ft-lbs. of torque at 1600rpm, as well as giving higher horsepower at the low end, the CP75 II's engine is coupled with a two-speed planetary drive for greater pushing power and jobsite performance.

Access and service to the engine, hydraulics and electrical is made easy by the single piece forward raising hood, access door in the hopper, and class-leading layout.

## 3 Track System

With 58" (147cm) of ground contact, the CP75 II's 12" (305mm) steel or optional poly-pad tracks give the paver exceptional balance and traction over a wide variety of bases. The hydraulically self-tensioning tracks are supported by 6 bogeys each, providing greater ground support and balance to the machine. Each CP75 II comes standard with rock guards that give added protection to the already robust track system.

## 4 Screenshot Mounted Controls

Designed around the operator, the CP75 II elevates crew comfort and performance with its dual control stations that maximize visibility and ergonomics. Both control stations are screed mounted, a feature that keeps them relative to the operator at all times. Each station features direct connect cable steering levers and intuitively organized switches. The CP75 II also features a 4.5" (114mm) LED display that provides up to the second information on engine performance and instrument gauges.



*Access and service to the engine, hydraulics and electrical is made easy by the single piece forward raising hood, access door in the hopper, and class-leading layout.*

*The placement of the controls enables class-leading operator visibility around the machine, as well as to the augers and screed for close monitoring of material flow and head of material.*



# MATERIAL DISTRIBUTION

Bringing together innovation, reliability and performance, the CP75 II material distribution system is rooted in exclusive, proven technologies and in an unwavering commitment to contractor focus. From making it easier to clean to elevating paving performance and quality, the CP75 II truly sets a new standard in its class.



**Choice In Conveyor Systems**  
**Chain Slat Or Patented HFMC**

## Choice In Efficient Material Delivery

Offering a choice in material delivery systems, the CP75 II can be fitted with either a chain/slat conveyor or the revolutionary High Flow Material Conveyor™. Featuring dual, heavy-duty 35.5" wide independently controlled conveyors, the standard chain/slat system offers robust reliability and superior productivity. For the commercial-class' most efficient conveyor system, the patented and exclusive High Flow Material Conveyor™ provides a horsepower reduction up to 75% compared to traditional conveyors. Utilizing dual 35.5" heat and oil resistant rubberized belts firmly fixed to a traditional chain and slat system, the HFMC system also leads the industry in eliminating mix segregation for the highest mat quality.

The CP75 II's innovative frame design eliminates the need of under hopper clean out required on other wide-conveyor pavers in its class, as material carry over falls between the tracks. With either conveyor system, contractors can simplify their end of day clean out and achieve longer lifecycle of their conveyor systems.



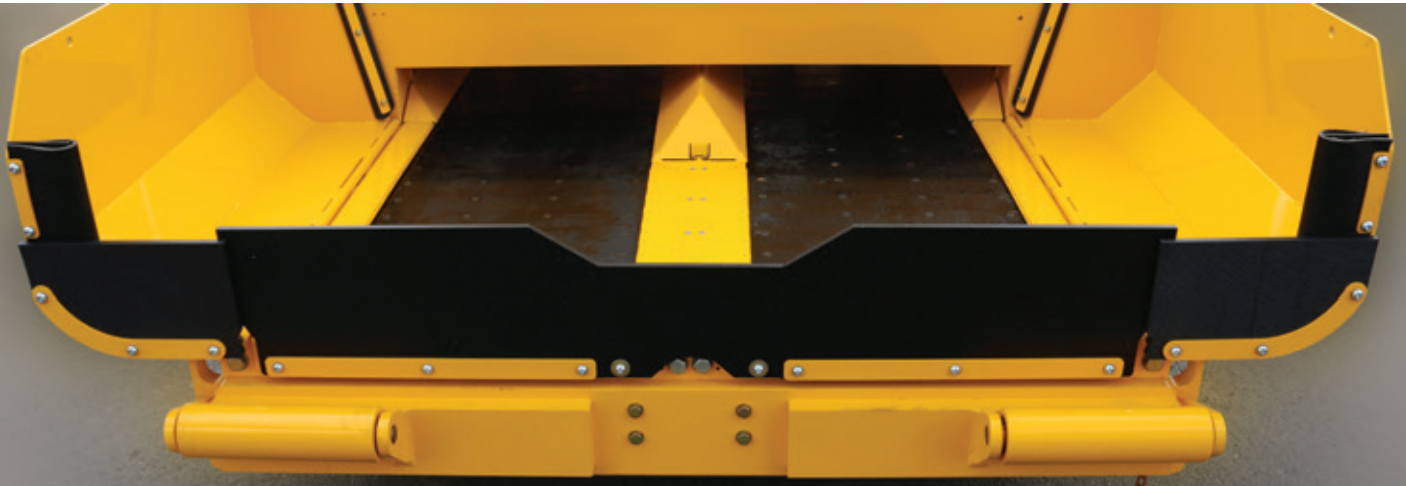

## Heavy-Duty Floor Plates

Like all Carlson commercial-class pavers, the CP75 II utilizes 3/8" (9.5mm) heavy-duty, 500 Brinell-rated steel floor plates for longer lifecycle and better performance. These class-leading floor plates are also fully replaceable, enabling contractors to rebuild their machine for even longer machine lifecycle and greater return on investment.

## Augers And Conveyors

The CP75 II employs replaceable 9.5" (241mm) diameter 500 Brinell-rated steel auger flights and class leading auger bushings. Spinning at 100rpm, the platform's augers efficiently move material outboard towards the endgates for uniform mat quality at wider widths.

## Horizontal Sliding Damper Doors

A Carlson exclusive feature, the horizontal sliding damper doors on the CP75 II keep obstructions, such as utility boxes, from damaging them while open. Able to be infinitely adjusted from fully open to closed, contractors are able to utilize the doors' tunnel effect for wider width paving. The horizontally sliding doors also prevent material from falling when traveling across the jobsite to the next pull.

## Sonics And Automation

For more even head of material at any width, the CP75 II is available with sonic augers and hydraulic tow point that automatically adjust the material flow for better mat quality. The CP75 II is also prewired as standard to accept grade and slope automation systems, including those sold by MOBA®, Topcon® and TF Technologies®.



# SCREED

Amongst commercial-class pavers, it is only Carlson's CP platforms that carry a Carlson screed. Engineered and built with over 30 years of industry-leading front-mount screed know-how, Carlson's EZC815 screeds deliver unparalleled mat quality and unmatched performance across a wide array of paving applications.



## Award Winning Highway-Class Mat Quality In A Commercial-Class Screed

### Highway-Class Features

Just like its highway-class screeds, renowned for their award-winning mat quality, Carlson has built in many of its industry-leading innovations and technology into the EZC815 commercial screed. Standard with state-of-the-art electric heating elements for clean, even heat across the main and extension plates, the EZC815 also incorporates with each element a full length hold down for better heat transfer to the plate. Add in the spring loaded endgates, innovative screed deck cone system for easy leveling, manual extension height, and crown adjustment, the EZC815 has the most standard screed features in its class.

### Screed Plates

Built with the Carlson class exclusive 2% taper, a feature that improves outboard flow of material regardless if the augers are on, the EZC815 screed utilizes a 16" (406mm) deep main screed plate and 8" (203mm) deep extension plates. Each plate is made of 3/8" (9.5mm) 450 Brinell-rated hardened steel, giving contractors leading plate lifecycle and unparalleled mat quality. The EZC815 also has class leading adjustable pre-strike offs tightly fitted to the main, a feature that allows little to no damage to occur when obstructions are bumped or hit due to poor elevation.





## Options For Customization

Contractors are able to add enhanced versatility and customization to their EZC815 through an array of class-leading attachments and functions. Able to be added anytime, contractors can tailor their screed to the demands and requirement of any job including:

- The Carlson Safety Edge endgate produces seamless, extruded 30° mat edges that eliminate the need for hand tamping. Standard with heat, the Carlson Safety Edge is able to be adjusted from 30° to joint matching with its integrated, externally mounted jack.
- The 12" (305mm) and 18" (457mm) Integral Berm option enables contractors to construct a seamless 4" (102mm) outside edge rise berm curb through quick manual adjustments.
- Power Crown can be easily added to the EZC815's crown assembly, giving contractors the ability to hydraulically adjust the screed from 3" (76mm) crown to 1" (25mm) invert.

# EZC815

## Extensions

Providing optimal rigidity at wide widths, the EZC815's extensions feature 2" (51mm) heavy-duty chrome rods with adjustable slide track bushings, limiting movement in the extensions and reducing component wear. Each extension of the EZC815 has externally accessible angle of attack adjustments that can be adjusted on the fly.

These features, and the ability of contractors to easily level the screed, give the platform longer lifecycle and ensure leading mat quality in a commercial class screed.



# OPTIONS & SPECS



## Customized To Fit Contractor Needs

With its ability to be customized to the needs of the contractor, the CP75 II is available with a wide array of options and attachments that elevate performance, comfort and visibility of the paver platform. Ranging from hydraulic tow points to power crown on the EZC815 screed, all of the CP75 II's options are able to be easily bolted on allowing contractors to add additional versatility and ability when needed. Simply put, no other paver in its class can match the customizability of the CP75 II.



### PERFORMANCE

- Sonic Augers
- Hydraulic Tow Points
- Poly-Pad Tracks
- Oscillating Push Roller
- Truck Hitch
- 7 LED Flood Light Package



### CONTRACTOR FOCUS

- Umbrella
- Beacon Light
- Screed Seat Mount
- 2nd Washdown Hose Reel
- 12v Aux. Charger Kit
- Additional RH Functions
- Slide Out Walkway Extensions



### MAT QUALITY

- Depth Crank Indicator Kit
- Heated Endgate Kit
- Choice of Depth Crank Thread
- Cut Off Shoes
- Safety Edge
- Integral Berm
- Power Crown



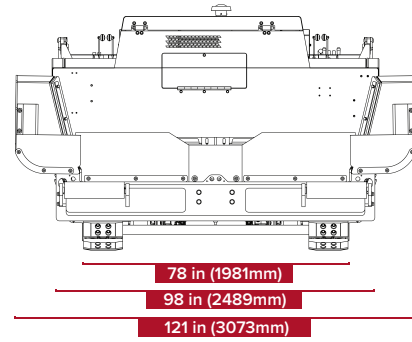
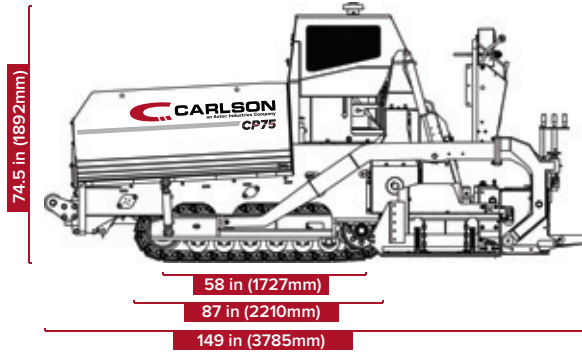

## DIMENSIONS

Total Weight	17,000 lb (7711kg)
Tractor Weight	14,000 lb (6350kg)
Screed Weight	3,000 lb (1361kg)
Hopper Capacity	8 Tons (7.25 tonnes)
Hopper Inside Width Opening	10 ft (305cm)
Hopper Dump Clearance	24.75 in (629mm)
Load Angles	15° Forward/15° Reverse

## ENGINE

Engine	74hp (55kW) Deutz 2.9 L4
EPA/EU Emissions Standard	Tier IV Final/Stage IV
Drive System	2 Speed Planetary
Track Type (Standard)	12" (305mm) Steel
Max. Pave Speed	155 fpm (47.2m/min)
Max. Travel Speed	255 fpm (77.7m/min)
Max. Reverse Speed	255 fpm (77.7m/min)

## COMPONENTS

Floor Plate Thickness	3/8 in (9.5mm) 450 Brinell-rated
Conveyor Width	35.5 in (902mm)
Damper Doors	Dual Horizontally Sliding
Auger Diameter	9.5 in (241mm)
Auger Flight Thickness	1/2 in (13mm) 500 Brinell-rated
Max. Auger Speed	100 rpm

## CAPACITIES

Fuel Tank	28 gal (105.9L)
Hydraulic Tank	20 gal (75.7L)
Cooling System Capacity	4 gal (15.1L)
Washdown Tank	5 gal (19L)
Electrical System	12v w/ 95 amp Alternator
Generator	14.4kW Belt Driven

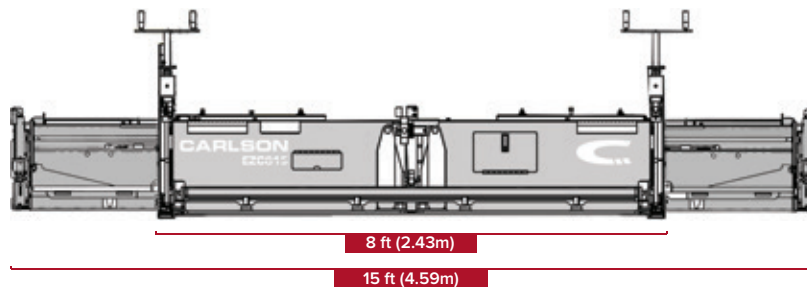

## EZC815 SCREED

Standard Paving Width	8 ft-15 ft (2.43-4.59m)
Max. Paving Width	15 ft (4.59m)
Paving Depth (Min/Max)	.25-8 in (6mm-203mm)
Main Plate Depth	16 in (406mm) Center 14 in (356mm) Edge
Main Plate Thickness	3/8 in (9.5mm) 450 Brinell Rated
Extension Plate Depth	8 in (203mm)
Extension Plate Thickness	3/8 in (9.5mm) 450 Brinell Rated

Screed Heat Source	Electric Heating Elements
Endgates	Spring Loaded
Crown Adjustment	Manual Adjustment
Crown/Invert	3 in (76mm) / 1 in (25mm)
Extension Height Adjustment	Manual Adjustment
Vibration	0-3000 vpm

01-0219

# CP75<sup>III</sup>



**CARLSONPAVINGPRODUCTS.COM**

MOBA is a registered trademark of MOBA Mobile Automation AG. TOPCON is a registered trademark of Topcon Corporation. TF TECHNOLOGIES and MINI-LINE are registered trademarks of TF Technologies A/S. Deutz is a registered trademark of Deutz Corporation.

Featured machines in photography may include additional equipment for special applications, optional equipment, and prototype machines.

Continually improving our products, materials and specifications are subject to change without notice. © 2019 Carlson Paving Products, Inc. All Rights Reserved.

