



Half-Lane Cold Planer

RX-600

ENGINE

RX-600e: Tier 4F; Cummins® QSX-15 675 hp (503 kW) @ 1,850 rpm
 RX-600ex: Tier 3; Cummins® QSX-15 630 hp (462 kW) @ 1,850 rpm*

WEIGHT

3 Track - 60,560 lbs (27,469 kg)*
 4 Track - 63,480 lbs (28,794 kg)*

*1/4 tank fuel; no water, 86" cutter housing & drum





Roadtec — An Astec Industries Company

Roadtec, Inc. is proud to be a part of the family of companies that make up Astec Industries, Inc. Founded in 1972, Astec Industries, has grown to become America's leading manufacturer of equipment for asphalt road building, aggregate processing, oil, gas and water well drilling and wood processing. Roadtec continues to be an industry leader together with Astec Industries, by applying Astec's model of creative thinking bolstered by a corporate culture renowned for putting customer service first.



THE ROADTEC DIFFERENCE: DELIVERING QUALITY AND INNOVATION WITH SUPERIOR CUSTOMER SERVICE

Dependability

Roadtec has been manufacturing innovative, heavy-highway equipment since 1981. We continue to grow and add new products, yet our personal connection to our customers and our ability to respond immediately to your needs is even stronger.

Customer Service

Our customers benefit from our strong focus on customer support after the sale. In-the-field service technicians live in the regions where they work and respond quickly. 24/7 parts support will get you the right parts fast, and at a fair price. Our product specialists will train your people on any newly purchased machine, and we also offer industry-leading training at our state-of-the-art training facility or in the field.

Count on Roadtec Equipment

We don't build roads. We make the equipment so you can cost-effectively build and maintain the world's roads. With the Roadtec heavy-duty design, we are able to keep your machine working longer while lowering maintenance and operating costs. We are also able to make your operators more comfortable and confident with our user-friendly design and our customization for special projects.

WELL-BALANCED & POWERFUL, THE RX-600 OFFERS YOU SOLID DESIGN FEATURES AND EASY-TO-USE SYSTEMS

Power, Maneuverability and Weight Balance

To perform all the functions of the milling operation, a cold planer requires a delicate balance of weight and power. The weight of this machine is balanced over the cutter, to ensure excellent traction while maintaining the desired depth of cut. With proper balance, the machine's power remains consistent while following trucks through tight turns or in adjacent lanes.

Choose Either Three or Four Tracks

With the RX-600 you can select either three or four tracks. Cold planers with three-track suspensions are more maneuverable in the cut and lower in weight. Four-track machines provide greater tractive effort and flotation.

RX-600 Cold Planers: High Productivity & Low Cost of Ownership

The RX-600 offers you solid design features, systems that are simple to troubleshoot, and parts that are non-proprietary and cost-effective. Plus you get exclusive features like Guardian® remote telematics system, Edge™ extended equipment warranty, choice of drum tooling, and 24-hour Roadtec customer support.





MORE POWER, EFFICIENCY, AND MANEUVERABILITY

It Starts with a Strong Frame

Roadtec builds the mainframe from extremely strong A656 grade 80 steel. This steel has twice the yield strength as the mild steel used in other machines on the market. Roadtec frames are very strong and rigid without adding unnecessary weight.

Fuel Economy & Engine Performance

Having the proper balance of weight and horsepower combined with the latest in engine technology ensures that every unit of fuel being burned is not wasted. This makes the RX-600 the most fuel-efficient machine we have ever built.



Keyway Steering

Steering of this machine is done from the tops of the front legs using steering keys that are easily replaceable. This innovative design requires no linkage under the primary conveyor between the front legs, which adds to the overall accessibility of the machine. Four steering modes enhance the machine's agility, allowing it to produce through tight turns. Steering modes include, crab, coordinated, rear only, and front only.

A LARGE PLATFORM WITH INTUITIVE CONTROLS, AND OPERATOR FRIENDLY ENGINEERING MAKES THE RX-600 EASY TO USE



Controls

Simplified controls allow for easy operation of the machine from either side of the platform. With multifunction joysticks and accessible controls, operating the machine is much easier. The controls are designed to be operated with one hand to allow for truck signaling.

Vibration Isolators

Rubber vibration isolators have been used to eliminate destructive vibration throughout the cold planer. Eliminating the vibration also makes the machine quieter while rubber mounts underneath the operator's platform provide more comfort.

Safe & Functional Platform

The operator platform is conveniently accessed from the right or the left side. Two control stations allow machine operation from either side.





Dust Extraction System

The RX-600e is now equipped with a standard dust extraction system for improved operator comfort and safety. The dust extraction system removes dust and debris from the milling operation through a hydraulic fan at the primary conveyor. The dust is ejected at the end of the secondary conveyor into the dump truck. As the dust is ejected, the material exiting the secondary conveyor belt helps to channel the fine material into the dump truck. This lowers the potential for strong wind to carry fine material back toward the milling machine.

Conveyor Efficiency

The cut material is easily handled by the 32" (813 mm) wide secondary conveyor with 1" (25 mm) tall molded cleats, and infinitely variable speed. Each conveyor also features self-cleaning pulleys which release wet material from the conveyors to ensure maximum efficiency. Canvas conveyor covers also come standard providing easier access.

Conveyor Swing

Mobility is critical. The secondary conveyor on the RX-600 swings 60° to the left and right. This feature makes it possible to mill tight turns, and send material to trucks in an adjacent lane. Conveyors feature infinitely variable speed and self-cleaning head and tail pulleys.

Sound Absorption

The engine is cooled by a variable speed fan that reduces noise by performing at a level determined by engine load.

A UNIQUE AND DURABLE CUTTER HOUSING DESIGN INCREASES COMPONENT LIFE, PRODUCTION RATES, AND EFFICIENCY



Cutter Housing

The cutter housing and drum are completely modular allowing it to be easily interchanged with other housings and drums of different widths. The inside walls of the cutter housing are fully lined with replaceable chromium-clad wear plates to ensure the housing withstands the abuse of the milling operation.

- A material brace on the front moldboard applies even pressure to the front edge of the cut for excellent material sizing
- Bolt-on tungsten carbide scraper blades at the rear moldboard add to the housing's toughness
- Cutter housing is made of T-1 steel (350 BHN)
- Adjustable endgates with replaceable shoes at the high-wearing front and rear corners.
- Replaceable, 1/2" (12.7 mm) chromium-clad (600 BHN) wear plates cover all potential wear areas (shown on right & shaded blue)

Dual Spray Bars

Two independent stainless steel spray bars positioned at the front and rear of the cutter housing provide increased tool life and dust control. Each spray bar can be controlled independently or both can be adjusted from a master control. Spray system can be easily connected to air system for quick purging and winterizing.

Adjustable Moldboards

The angled rear moldboard can be set in a fixed position or in float mode. Float allows the moldboard to adjust up and down with the elevation of the cut, and the height of the rear moldboard is fully adjustable. When the moldboard is fully raised the engine is shut down for safety. Both the rear and front moldboard on the RX-600 are angled in toward the drum by 10°. This allows less material to accumulate around the drum, which increases component life, production rates, and efficiency as well as leaving less material to clean up at the end of a pass.





HIGH PERFORMANCE, HEAVY DUTY DRUMS INCREASE COMPONENT LIFE, PRODUCTION RATES, AND EFFICIENCY

Cutter Drums

Specialty cutter drum designs are available from wide spaced excavating patterns to fine spaced micro milling patterns as well as double hit drums to improve production without sacrificing quality of cut. Multiple tooling options are available including Sollami, Kennametal and Keystone Quick Change systems. A wealth of experience and engineering expertise is readily available to design drums best suited for your application that will offer you the lowest operating costs and maximize your profitability. All of the cutter drums are designed and manufactured by Roadtec utilizing three-dimensional solid modeling and highly accurate robotic welding.

Engineering Expertise

There is no substitute for outstanding design. Roadtec engineers put an enormous amount of time and effort into designing machines that perform at the highest level in every possible application. Various lacing patterns are available on each cutter drum allowing the machine to obtain the desired surface texture. Innovative options such as the VCS® system are available to allow machines to cut at different widths with minimal effort.

Cutter Drum Gearbox

Heavy-duty, high-torque gearboxes transfer power from the drive belts to the cutter drum. Shear couplings are also used as a protective measure. If the drum strikes a buried obstruction, the shear coupling will separate the input shaft from the gear box to protect the engine. The coupling is easily and quickly replaceable.

Cutter Access

Changing cutter teeth is much easier with the rear moldboard fully rising to expose cutter teeth. The rear moldboard slides vertically for a much cleaner tooth changing process. A safety disengage will shut off the machine when the moldboard is fully raised. A power pack will raise or lower the moldboard when the machine is off.

Drum Styles

- Standard 5/8" (16 mm) Single Hit Triple Wrap: The most versatile drum available. Good performance at varying depths.
- Double Hit Quad Wrap: Drum designed for typical cut depths for overlays. These drums can improve forward speed of machine without sacrificing surface texture and increase tooth life.
- Single Hit Profiling: For 4 inch or less of removal at a normal speed of 40 to 50 FPM.
- Single Hit Micromill: Fine milling, For 2 inch or less of removal at slow speeds (20 to 25 FPM to leave straight lines).
- Double Hit Micromill: Fine milling, For 2 inch or less of removal at higher speeds (40 to 50 FPM to leave straight lines).

*all speeds can vary and are dependent on material, tooling and other factors.

Roadrunner™ Drums

Quad Wrap, double hit drums allow the machine to travel at higher speeds while maintaining a consistently smooth surface pattern and increasing the tooth life. This allows contractors to maximize production and still leaves a good surface for overlays.

Exclusive VCS® System

The Variable Cutter System allows the RX-600 to cut at widths of 24" (610 mm), 36" (914 mm), 48" (1,219 mm), and 60" (1,524 mm) without changing the cutter housing. A hydraulically adjustable segmented rear moldboard is included with VCS® allowing the machine to easily adapt to the different cutting widths.

Drum Options

Roadtec offers a number of drum options to allow smooth machine operation in different applications. With a variety of widths and tooth patterns available, you can select the drum best suited for your projects. Various tooth patterns will yield their best surface at different speeds.

1. Roadrunner™ Double Hit Quad Wrap - 100 FPM
2. Standard 5/8" (16 mm) Single Hit Triple Wrap - 100 FPM

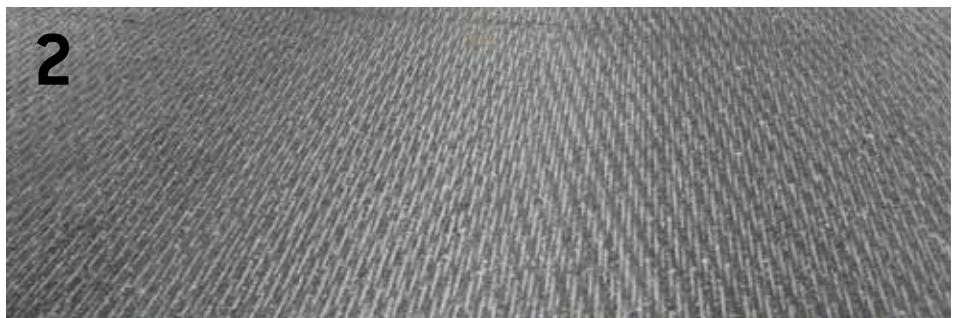

THE RX-600 SAVES YOU TIME & MONEY BY DELIVERING QUALITY MILLING TO ACHIEVE SMOOTHNESS



Milling for Smoothness

When smoothness of the finished pavement is important, it's critical to start with a level milled surface. Then the paver has every opportunity to get it right. Today's cold planers with their extremely accurate grade and slope controls can be used to level the road in longitudinal and transverse directions. Using current grade and slope control technology will result in a much smoother surface, and many areas now require smoothness specifications on milled surfaces. Roadtec now offers the ACE™ grade and slope control package for easier operation. The sonic sensors scan the surface 40 times per second and coordinate with the hydraulic system to adjust the leg tubes of the cold planer so the resulting milled surface will conform to your specification.

Milling Advantages

Milling an even pavement before repaving will make resurfacing easier and will assure you the best possible situation for achieving smoothness, especially if your cold planer is equipped with automated grade and slope controls. Plus, you can turn the reclaimed material into money by recycling it in your own asphalt plant or selling it to an asphalt producer.

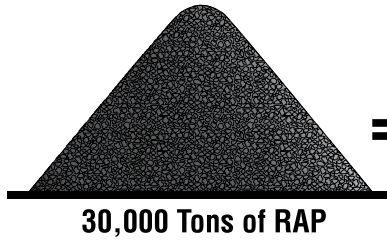

=

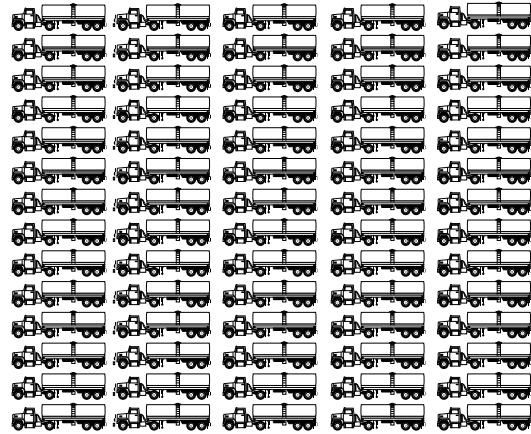

**70 - 6,000 Gallon Transport Trailers
and 28,200 Tons of Clean Aggregate**

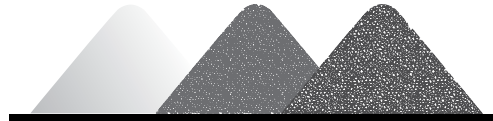

A 30,000 ton pile of RAP with an average 6% liquid AC content is the equivalent of about 28,200 tons of clean aggregate plus 420,000 gallons of liquid asphalt! This material can replace virgin materials in new mix. The recycled materials are as good as virgin rock or AC.

Overlays can crack and re-rut but milling and then overlaying the pavement prevents re-rutting and also provides better density numbers.



Original Roadbed



After Milling



After Overlay



After Overlay



After Traffic



After Traffic

AUTOMATE YOUR MACHINE ELEVATION IN THE MOST PRECISE AND USER FRIENDLY WAY POSSIBLE

The ACE™ Grade and Slope Control

The ACE™ Grade and Slope Control system is designed to automate the elevation of your machine in the most precise and user friendly way possible. New graphic displays allow the crew to easily select, calibrate, and control sensors with minimal time and effort. The sensors used to measure depth and slope are continuously monitored and displayed on three separate control panels keeping the entire crew on the same page at all times.

Control Panels

The color control panels are clearly labeled for simple, straightforward operation. Selecting wire rope, sonic, and slope sensors is easily done from any of the three screens. Setting the values and transitioning among the different sensors is done from the same screen view on the control panel. This simple setup eliminates the need to access different menus or use excessive button combinations to make changes while the machine is operating.

Automatic Calibration

The ACE™ system provides the ability to automatically calibrate specific hydraulic parameters ensuring the machine consistently achieves the precise depth. The automatic calibration feature is easily accessible through the ACE™ control panels.

Additional Sensors

The ACE™ system can easily incorporate additional sonic sensors. Sonic averaging skis can be installed on both sides of the machine to average depth variations and minimize drastic deviations in the machine's elevation. The sensors used on these averaging skis will appear on the ACE™ control screens when they are plugged in for use on the machine.





RX-60

SET CHANGE TOOL



PROTECT YOUR INVESTMENT AND KEEP OPERATING COSTS LOW BY MONITORING YOUR MACHINES IN REAL TIME

The Roadtec Guardian® Telematics System consists of software, on-machine viewing screens, and wireless signal boosters to send and receive data at the machine. Numerous functions such as engine data and fuel consumption can be viewed at the machine or on your computer screen from a remote location.

Help from Roadtec service is only a phone call away! They see the same information you see and can guide you through the fix or do it for you.



Monitor & Troubleshoot

- Fuel Consumption
- Engine Codes
- Alarms
- Starting Circuit
- Cutter Circuit
- Auto Water Circuit
- Conveyor Speeds
- Propel Functions
- Load Control
- Steering Circuit
- Machine Production
- Grade & Slope
- Hydraulic Pressure
- Engine Dashboard

Real-time Machine Data

See everything instantly: from fuel consumption, fault codes, time to service intervals, machine speed, grade and slope settings, or even the exact location of the machine (via GPS).

Designed by Roadtec for Roadtec

Guardian® Telematics is for Roadtec customers who are looking to dramatically lower operating costs and increase productivity.

View Remotely and On-board the Machine

Log into the machine from your computer or you can view the information on the machine's display screens.

Strong Signal with Cell Booster

The connection to and from the machine is wireless and uses a cell booster to ensure a strong signal. If an Internet connection is unavailable at any given location, the on-board computer stores faults until the connection is restored and then sends the e-mail.

Your machine can be located by GPS using the Guardian® Roadtec Telematics system.



The screenshot shows the Guardian Roadtec Telematics System interface. At the top, there's a 'Setup Menu' button, the version '7.0.0.4', and a 'CONNECTED TO C WITH DATA' status. The machine model 'RX-600e' and 'Machine Serial No.' are also visible. Below this is a navigation bar with tabs for various machine functions: Alarms, Start, Cutter, Water, Conv, Propel, Tract Cont, Load Cont, Steer, Housing, Elevation, Hyd, Engine, TOPCON, Moba, and Mot. The main display area is divided into several sections:

- Engine Metrics:** Fuel PSI (N/A), Turbo Boost PSI (2.32), Engine % Load (19), Inlet Air Temp (89), Engine % Soot Load (1), Engine Speed (1069.5), Engine Hours (910.7), Engine Idle Hours (49.6), Total Idle Fuel Burn (75.8).
- Operational Metrics:** Travel Speed FPM (0), Fuel Tank Level (FULL), Total Fuel Used (7125.9), Avg. Gal/Hour (7.82).
- Fluid Levels:** DEF Fluid (E/F bar), Hours Until Service (113.6).
- Fault Codes:** Active Engine Fault Codes and PreviouslyActiveEngine Fault Codes tables with columns for Fault Code, FMI, and Count.
- Control Buttons:** FORCE REGEN, INHIBIT REGEN, Request Previously Active Fault Codes, and Clear Fault Codes.

At the bottom, a note states: "Active engine fault codes are displayed automatically and are not requested. You may request previously active fault codes (if not cleared) using the request button."

This screenshot shows the location tracking interface. On the left, a list of machines is displayed with their IDs and key metrics:

- RX-600 4022:** Fuel/Minute: 0, Idle Time: 0:00:00, Fuel Level: 30%, Engine Hours: 34, Hours Until Service: 196.
- RX-600 4005:** Fuel/Minute: 0, Idle Time: 0:00:00, Fuel Level: 53%, Engine Hours: 1124, Hours Until Service: 22.
- RX-900 2033:** Fuel/Minute: 52, Idle Time: 0:00:00, Fuel Level: 77%, Engine Hours: 1258, Hours Until Service: 188.

The main area is a satellite map of a region including Buenos Aires, Morón, San Justo, Lomas de Zamora, and Quilmes. A red location pin is placed on the map, corresponding to the machine ID 4022.

EXTRA FEATURES AND EASY MAINTENANCE ACCESS MAKE THE WORK GO SMOOTHER

Centralized Lubrication

The grease fittings are arranged in zones that are clearly labeled with recommended amounts to make preventative maintenance as convenient as possible.

Bolt-On Track Pads

Bolt-on style track pads are available allowing quick and easy replacement of worn pads.

Light Package Is Supplied

All models come with lights to illuminate key areas of the machine and two halogen magnetic work lights. Additional work lights are available.



Easy Engine Access

Roadtec cold planers offer the best engine access in the industry. A large hood opens hydraulically for complete access to the engine. Additional access doors are found at each service point.



Easy Clean-Up

The standard high pressure washdown system helps to keep the machine looking and running like new. The system includes wash down bars at conveyors and plenty of hose to reach all points of the machine.

Air Compressor Included

The RX-600 comes with a standard compressed air system. Two storage tanks and a compressor let you use your air tools for service and maintenance tasks.

Conveyor Access and Belt Tensioning

Each end of the belt on each conveyor can be independently tensioned. Keeping the belt tensioned properly ensures that the belt is tracking correctly, which improves belt life.

Electrical System

Standard 24 volt electrical system with 105 amp alternator. CAN-based electronics with on-board and remote diagnostics to allow simple trouble shooting throughout the machine.



CALL
1-800-PAVEMENT
Safety, Quality, Professionalism.

0-2990

OPTIONS

Miscellaneous

- Hydraulically folding secondary conveyors make the cold planers much easier to transport by greatly decreasing their length.
- Operator Station Canopy
- Automated Lubrication System
- Tow Hitch
- Guardian™ Totalizer
- Cameras

Tracks

- Three-track or four-track assemblies

Additional Lighting

- Night Light Package – Four 24v high intensity discharge lights enhance visibility for work performed at night
- SaberLight™ - (2) 92W, LED light panels

Auxiliary Power

- 4 kW Continuous Duty Hydraulic Generator

EDGE™ Extended Equipment Warranty

The EDGE™ Extended Equipment Warranty goes above and beyond power train or extended engine warranties currently offered in the industry by covering more components and repairs as well as covering repairs done by the customer for a term of 3 years or 3,000 hours on the machine and 5 years or 6,000 hours on the engine.

- 15 kW Continuous Duty Hydraulic Generator

Grade and Slope Control

- ACE™ Digital Grade and Slope Control System for operator and ground man
- Sonic Averaging Ski Package with one or two skis.
- Rear Leg Control System. Sonar Grade Control for rear elevation.

Cutter Systems

- Sollami®, Kennametal®, or Keystone® systems available.
- Profiling or Micro-Milling Drums (multiple widths and spacing available)
- VCS™ Variable Cutter System
- Roadrunner™ Double Hit

Cold-in-Place Recycling

- Dual Control Package For Bi-Directional Operation
- Cutter Housing Bi-Directional Package
- Cold-in-place Additive System



SPECIFICATIONS

ENGINE

- RX-600e: Tier 4F; Cummins® QSX-15 675 hp (503 kW) @ 1,850 rpm
- RX-600ex: Tier 3; Cummins® QSX-15 630 hp (462 kW) @ 1,850 rpm*

WEIGHT

- 3 Track - 60,560 lbs (27,469 kg)*
 - 4 Track - 63,480 lbs (28,794 kg)*
- *1/4 tank fuel; no water, 86" cutter housing & drum*

ELECTRICAL SYSTEM

- 24v system with onboard and remote diagnostics via Roadtec Guardian™ Remote Telematics System
- Two 8D batteries & 105 amp alternator
- Emergency engine shut-down; cutter disengages and engine shuts down when rear cutter door is opened.

PROPEL SYSTEM

- Hydrostatic drive with automatic traction control.
- Hydraulically controlled suspension. Manual and automatic.

SPEEDS FOUR-TRACK

- Travel 0-3.2 mph (0-5 kph)
- High working 0-163 fpm (50 mpm)
- Low working 0-110 fpm (34 mpm)

SPEEDS THREE-TRACK

- Travel: 0-3.2 mph (0-5 kph)
- High working: 0-127 fpm (39 mpm)
- Low working: 0-100 fpm (30 mpm)

TRACKS

- Direct hydraulic, planetary track drives. Bolt-on, replaceable poly track pads 12" (305 mm) wide.

TURNING RADIUS

- 4-track: 6'8" (2,032 mm). 3-track: 5'8" (1,727 mm)

OPERATOR STATION

- Left/right side full-function operator stations on shock-absorbing operator platform with joy stick controls

GROUND CONTROLS

- Ground controls for mold boards, emergency stop, horn, load-out conveyor, rear steering, end gates, and elevation.

CONVEYORS

- 32" (813 mm) wide endless, heavy-duty belts with 1" (25 mm) tall molded rubber cleats
- Canvas load-out conveyor covers and self-cleaning pulleys
- 120° load-out conveyor swing capability

STANDARD LIGHT & ELECTRICAL OUTLET

- 24v lights & 24v DC power outlets, 2 magnetic base work lights

SERVICE CAPACITIES

- Fuel tank..... 250 gal (946 l)
- Hydraulic fluid tank..... 90 gal (341 l)
- Water tank 800 gal (3028 l)

CUTTER SYSTEM FEATURES

MAXIMUM CUT DEPTH

- 13" (330 mm)

STANDARD TOOTH SPACING

- 5/8" (16 mm)

STANDARD TIP DIAMETER

- 44" (1,118 mm)

STANDARD DRUM SYSTEM

- Sollami® triple wrap, single hit drum with cutter bits for traditional milling
- Kennametal® drum optional

CUTTER DRIVE & GEAR BOX

- Bolt-on with mechanical v-belt drive. Automatic drive belt tensioning.
- W-40 Fairfield® cutter gear box with mechanical fail safe to protect engine from shock loads.

CUTTER SYSTEM OPTIONS

STANDARD CUTTER HOUSINGS & CUT WIDTHS

- 75" housing with 6'3" (1,905 mm) width cutter drum. (Three-track only)
- 79" housing with 6'7" (2,007 mm) width cutter drum.
- 86" housing with 7'2" (2,184 mm) width cutter drum.

OPTIONAL VCS® VARIABLE CUTTER SYSTEM

- Cutter housing with segmented rear moldboard capable of widths of 24" (610 mm), 36" (915 mm) & 48" (1,220 mm)
- Special VCS® housing allows change of cutting widths by only changing drum
- Maximum Cut Depth: 12" (305 mm)

GRADE & SLOPE AUTOMATION

- Mechanical System
- Digital ACE™ Grade & Slope Automation
- Digital Prewiring for ACE™ Averaging Ski
- ACE™ - Single Averaging Ski
- ACE™ - Dual Averaging Ski
- Moba® Rear System

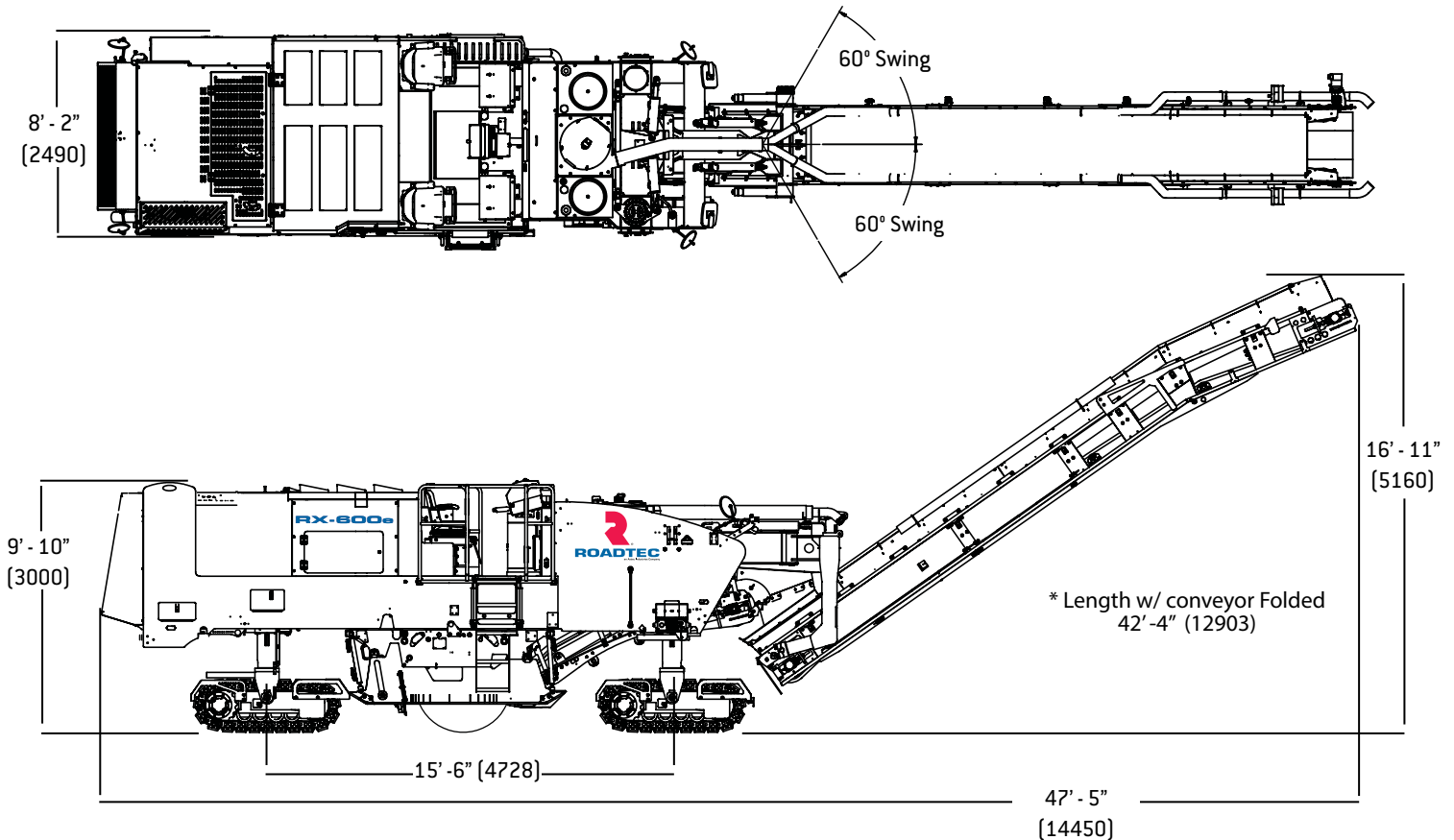

Dimensions in brackets are mm.

Specifications are subject to change without notice.

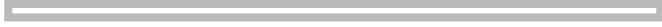
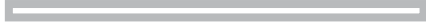

ROADTEC.COM

ROADTEC an Astec Industries Company

800 MANUFACTURERS RD • CHATTANOOGA, TN 37405 USA • 800.272.7100 • FAX 423.267.7104 • roadtec.com

033117



© 2017 Roadtec, Inc. All Rights Reserved