



## Half-Lane Cold Planer

# RX-700

### ENGINE

RX-700e: Tier 4 Final; Caterpillar® C18 800 hp (597 kW) @ 1,800 rpm  
RX-700ex: Tier 3; Caterpillar® C18 700 hp (522 kW) @ 1,900 rpm\*

\* ex machines for lesser regulated countries

### OPERATING WEIGHT

Three-Tracks: 77,380 lbs (35,099 kg)

Four-Tracks: 82,400 lbs (37,376 kg)

\*With ¼ tank fuel, 7' 2" cutter & empty water tank



## FEATURES

### **Heavy Duty & User Friendly**

Contractors seeking a high productivity half-lane planer will find it in the RX-700. Built with the Roadtec focus on balanced weight distribution, the RX-700 is a heavy duty machine which is simple to use and easy to maintain.

### **Versatile Three or Four Tracks Options**

With the RX-700 you can select either three or four tracks. Cold Planers with three-track suspensions are more maneuverable, lower in weight, and have less maintenance, while four-tracks machines provide greater traction and flotation.

### **Enhanced Operator Comfort and Precision**

The RX-700 has a left and right side full function operator station, enhancing productivity and visibility. A shock absorbing operator platform creates a smooth ride while joystick controls allow for precise maneuverability. Optimized water and dust extraction systems are features on the RX-700.

## Power and Efficiency

The RX-700 features increased power and ease of use with variable width cutter drums, high function conveyors, and automated elevation, load, and traction controls.

- **Variable Width Cutter Drums**

The RX-700 cuts up to 14" (356 mm) deep with standard widths of 6'7" (2,007 mm), 7'2" (2,185 mm), 8'2" (2,489 mm), and 10'6" (3,201 mm).

- **Versatile Secondary Conveyor Swing**

A 60-degree from center conveyor swing allows you to easily feed a truck in an adjacent lane or around a tight bend such as in a cul-de-sac. The traditional swing is only 40 degrees.

- **Convenient Folding Conveyor**

A folding conveyor is available as an option to aid in transport and loading.

- **Advanced Grade and Slope Controls**

The Automated Control of Elevation™ (ACE) system automates machine elevation through a combination of grade and slope sensors. The operator and ground crew can easily make changes to the grade and slope parameters, on the job and in real time. With the Auto Cut™ feature, the machine's rear elevation is automated as the machine enters each cut.

## Simple Maintenance and Long Wear Life

Powerful and well designed, the RX-700 offers solid design features, systems that are simple to troubleshoot, and non-proprietary parts. Plus you get exclusive features like our Guardian® remote telematics and diagnostics system.

- **Angled Moldboards**

Both the rear and front moldboards on the RX-700 are angled in toward the drum. This allows less material to accumulate around the drum, which means increased component life, production rates, and efficiency.

- **Dual Water Spray Bars**

The RX-700 has two independent spray bars to inject water into the cutter housing. The front spray bar is primarily for dust suppression, the rear spray bar cools the cutting teeth. When in automatic mode, the water system will only pump water while the machine is moving forward.

## CUSTOMIZATION OPTIONS

### GRADE AND SLOPE CONTROLS

- Roadtec Hydro-Mechanical Grade and Slope Control
- ACE Grade and Slope Control with Auto Cut
- ACE Single and Dual Averaging Ski Systems

### VERSATILE CUTTER SYSTEMS

- Profiling or Micro-Milling Cutter Drum Systems
- Cold-in-Place Recycling Packages

### ENHANCED VISIBILITY AND COMFORT

- 24V LED Night Light Package
- Operator Station Canopy- Hydraulic or Manual
- Secondary Conveyor Camera

### OPTIMIZED TOOLS AND EFFICIENCY

- Guardian® Totalizer
- Automated Lubrication System
- Hydraulically Folding Secondary Conveyor

# SPECIFICATIONS

## ENGINE

- RX-700e: Tier 4 Final; Caterpillar® C18 800 hp (597 kW) @ 1,800 rpm
- RX-700ex: Tier 3; Caterpillar® C18 700 hp (522 kW) @ 1,900 rpm\*

\*ex machines for lesser regulated countries

## WEIGHT

- Three-Tracks: 77,380 lbs (35,099 kg)
- Four-Tracks: 82,400 lbs (37,376 kg)

\*With ¼ tank fuel, 7' 2" cutter & empty water tank

## ELECTRICAL SYSTEM

- 24v system with onboard and remote diagnostics via Roadtec Guardian® remote telematics system
- Two 8D batteries & 105 Amp alternator
- Emergency engine shut-down; cutter disengages and engine shuts down when rear cutter door is opened

## PROPEL SYSTEM

- Hydrostatic drive with automatic traction control
- Hydraulically controlled suspension. Manual and automatic.

## SPEEDS

- 0-3 mph infinitely variable (0-4.8 kph)

## TRACKS

- Direct hydraulic, planetary track drives. Bolt-on, replaceable poly track pads 14" (356 mm) wide.
- Rear track width on 3-track machine: 16" (406 mm)

## TURNING RADIUS

- 4-track: 7' 9" (2,362 mm)
- 3-track: 6' 10" (2,083 mm)

## OPERATOR STATION

- Left/right side full-function operator stations on shock-absorbing operator platform with joy stick controls

## CONVEYORS

- 36" (915 mm) wide endless, heavy-duty belts with 1" (25.4 mm) tall molded rubber cleats
- Canvas load-out conveyor covers and self-cleaning pulleys
- 120° load-out conveyor swing capability

## STANDARD LIGHT & ELECTRICAL OUTLET

- 24V lights & 24V DC power outlets, 2 magnetic base work lights

## SERVICE CAPACITIES

- Fuel Tank .....340 gal (1,287 l)
- Hydraulic Fluid Tank.....100 gal (379 l)
- Water Tank .....1,100 gal (3,028 l)

## MAXIMUM CUT DEPTH

- 14" (356 mm)

## AVAILABLE CUT WIDTHS

- 6'7" (2,007 mm), 7'2" (2,185 mm), 8'2" (2,489 mm), 10'6" (3,201 mm)

## CUTTER DRIVE & GEAR BOX

- Bolt-on with mechanical v-belt drive. Automatic drive belt tensioning.
- W-50 Fairfield® cutter gear box with mechanical fail safe to protect engine from shock loads.

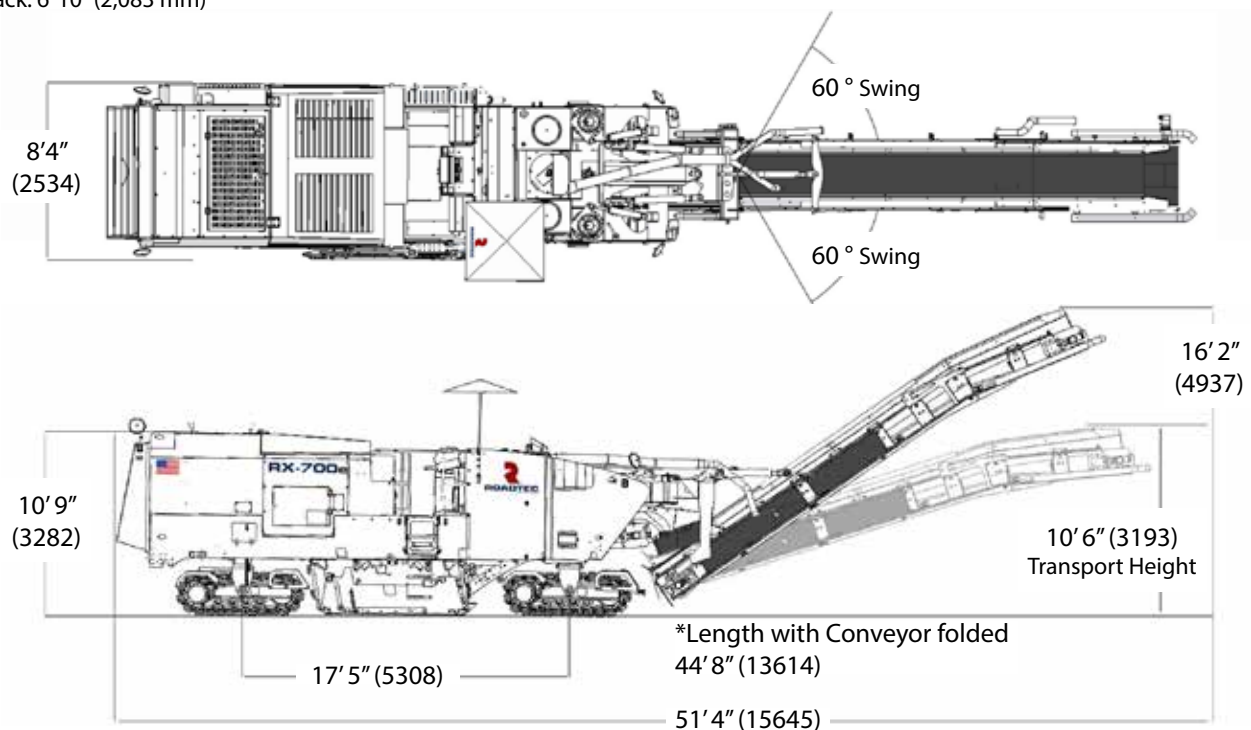

Dimensions in parentheses are mm.

Specifications are subject to change without notice.

**ROADTEC** an Astec Industries Company

800 MANUFACTURERS RD • CHATTANOOGA, TN 37405 USA • 800.272.7100 • FAX 423.267.7104 • roadtec.com

3.700.01



© 2019 Roadtec, Inc. All Rights Reserved