

# SX-5e

## STABILIZER-RECLAIMER



## STABILIZER-RECLAIMER

Dedicated to Your Success.<sup>SM</sup>

### Engine

Cummins® QSG-12

Tier 4F; 513 hp (382 kW) @ 1,900 rpm

### Shipping Weight

59,017 lbs (26,770 kg)

\*120 gal fuel & water/injection system

### Cutting Width

96" (2,438 mm)

### Max Cutting Depth

16" (406 mm)



### **Roadtec — An Astec Industries Company**

Roadtec is a proud part of the family of companies that make up Astec Industries, Inc. Founded in 1972, Astec is America's leading manufacturer of equipment for asphalt road building, aggregate processing, wood processing, and oil, gas and water well drilling. Roadtec leads the industry by applying Astec's model of creative thinking bolstered by a corporate culture that puts the customer first.



## THE ROADTEC DIFFERENCE: DELIVERING QUALITY AND INNOVATION WITH SUPERIOR CUSTOMER SERVICE

### **Quality and Reliability**

Since 1981 we've manufactured innovative, heavy-highway equipment. We offer the most reliable and maintenance-free pavers in the industry. Our heavy-duty designs keep your machine working longer, lowering your maintenance and operating costs. Your operators work comfortably and confidently with our user-friendly, ergonomic designs.

### **Leading Innovation**

As the original innovator of the Shuttle Buggy® material transfer vehicle, Roadtec provides the industry's most refined pavement placement solutions. Our patented technologies enable nonstop paving and eliminate segregation, while providing the optimum balance of horsepower and maneuverability.

### **Customer Focus**

As we grow and develop new products, our personal connection to our customers remains steadfast. Our field service technicians live in the regions where they work. Our engineering, manufacturing and service departments are in the same building, enabling all teams to work together and provide quick and comprehensive customer service, 24/7. Our skilled and experienced technicians provide comprehensive training at our state-of-the-art training facility or your location.



## POWER AND PERFORMANCE IN HARSH ENVIRONMENTS

Roadtec's Stabilizers/Reclaimers are designed and crafted to solve the challenges presented when working with terrain that has limited bearing capacity. Roadtec stabilizers are ideal for soil stabilization and reclamation. The Roadtec suite of SX stabilizers is able to treat various soils by mixing the material in-place with water or other additives to create a more suitable base material.

The SX-5 Soil Stabilizer/Reclaimer is ideal for soil stabilization and light reclamation. The clean running 513 hp SX-5 provides high performance power through a hydrostatic drum drive. Whether you need to prepare a new surface or recycle existing road surfaces, the ability to cut up to 96 inches wide and 16 inches deep makes the SX-5 ideal for soil stabilization and road rehabilitation.

# DURABILITY AND FLEXIBILITY

The SX-5 is constructed with a durable frame fabricated from A656 grade 80 steel, which has twice the yield strength as steel used in competing machines.

## Heavy Duty Tires

The wheels on the SX-5 are heavy duty, three piece wheels that prevent rim slippage and tire failure. Tires are deep tread, high-flotation tires that make sure you get the most from the SX-5's power and maneuverability.

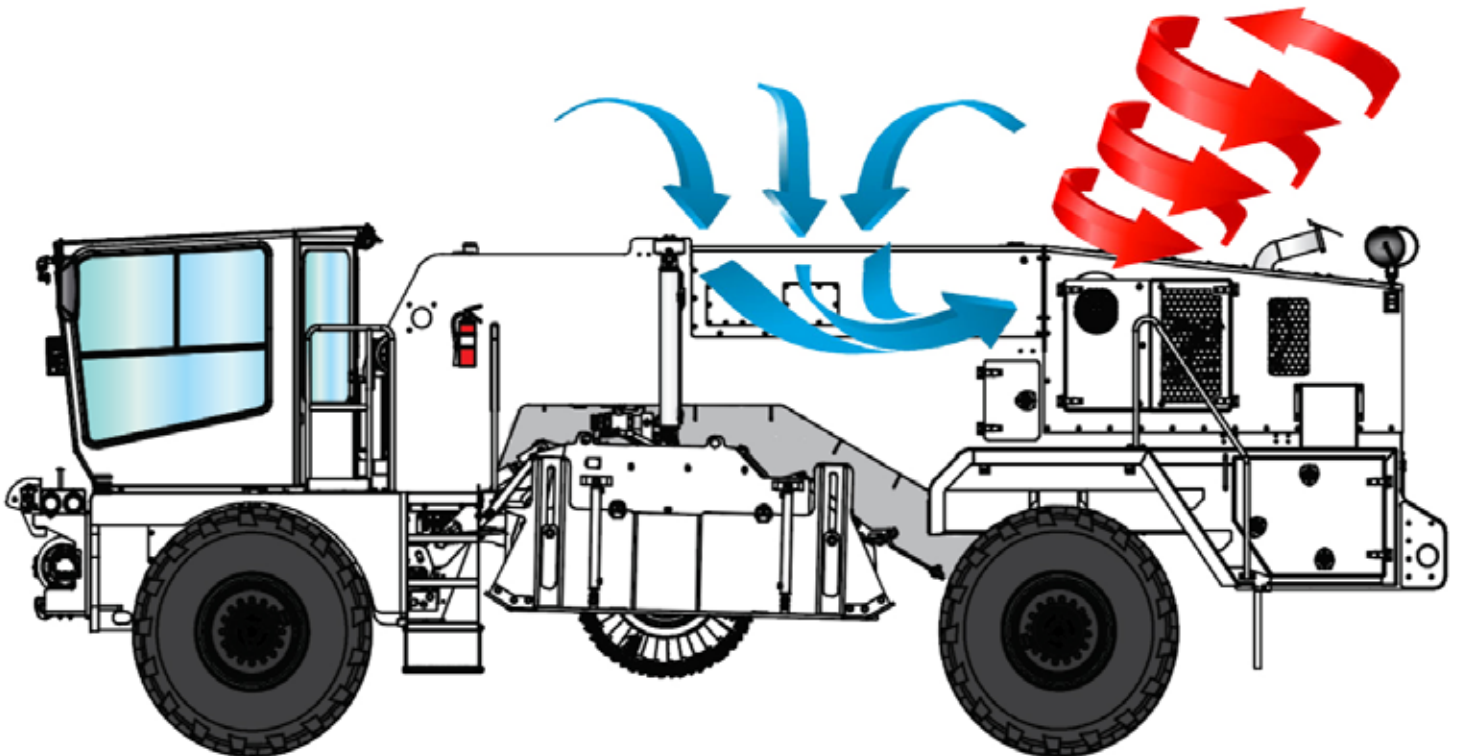

## EFFICIENT COOLING SYSTEM

The SX-5's cooling system brings air from the top of machine, where it is the cleanest, and exhausts it through the rear radiator package. Pulling air in this way limits the dust that travels through the cooling system. A variable speed fan provides efficient cooling based on engine demand, and an auto fan reverse at startup allows for cleaning of debris.



## SAFETY AND ERGONOMICS MAXIMIZE PRODUCTIVITY

While efficiency and durability are essential to a stabilizer's success, it cannot be at the expense of safety. That's why Roadtec operator cabins are designed to enable operators to work safely and securely. The cabins are temperature controlled, pressurized, and dust free. Soundproofing protects hearing and facilitates clear communications.

The design of the SX-5 makes certain the operator is safe and comfortable. Ergonomic seating and intuitive, easy to reach controls make sure your operator is working efficiently and safely, without sacrificing productivity. Operators are protected from the elements and are able to work safely, while not being distracted by weather. They can remain safely focused on the job at hand.

### **Supreme Comfort for Less Downtime**

The operator is comfortable with enough space to work comfortably and productively. The temperature-controlled cabin provides protection from weather and elements. Operators can work in cold and heat as the cab has a fully enclosed and pressurized A/C and heating system.

## TEMPERATURE-CONTROLLED CABIN

The operator is comfortable with enough space to work comfortably and productively. The temperature-controlled cabin provides protection from weather and elements. Operators can work in cold and heat as the cab has a fully enclosed and pressurized A/C and heating system.



## Easy Steering Options

The operator is free to choose from four steering options to achieve ideal maneuverability. Steering is easily controlled via joystick and allows quick response and smooth changes. Operators can choose from 4 modes to ensure they have the most control. They can choose coordinate steer, crab steer, front steer only, or rear steer only. The mode is always plainly in view on the display screen.

## Convenience at Your Fingertips

Simple and straightforward joystick controls are clearly marked and effortlessly accessible from the operator's ergonomic seat. All controls are perfectly calibrated for maximum efficiency and allow easy operation of multiple functions and options.



## Unparalleled Visibility

The operator enjoys unobstructed sight lines, and for those areas that are inaccessible, there are cameras, with easy view display screens. The operator station will shift from left to right side of machine and pivot from the straight ahead position to 90° left or right.

The SX-5 includes a high resolution back up camera standard. The camera provides additional visibility when the machine is in reverse. A screen inside the cab displays the area directly behind the SX-5 as soon as reverse is selected. The back up camera adds a level of comfort and convenience when navigating around other machines and obstacles.

Users are also provided the option of additional cameras, including up to four additional cameras custom installed where you want them, on the back, sides, or front of the machine, or even under the machine. Images from all these cameras are easily and clearly viewed on display screens.





# RELIABLE PRODUCTIVITY AND CONSISTENCY

Roadtec is focused on maintaining productivity and comfort. The SX-5 can perform consistently even in the toughest and most irregular surfaces.

## Balanced Weight and Wheel Power

Weight is evenly distributed between 2 axles and balanced over the cutter. Even distribution enables for optimal controlled power. The SX-5 is all-wheel drive.

Four drive pumps deliver 100% traction control, enabling the SX-5 to perform consistently in the most challenging environments. The weight is distributed with functionality, productivity, and safety in mind. This way, traction is constant. The balanced 4-wheel drive allows operator to adjust the machine to perform best in any situation.

## Easy to Transport

Stabilizers need to move among job sites easily and efficiently. The ideal weight balance of the SX-5 makes it easy to transport without burning excessive fuel.

# MAINTENANCE FEATURES MAKE THE JOB EASIER

Large side doors and slide-out battery racks provide even better maintenance access. A remote air compressor is included to power pneumatic tools and make changing teeth safe, simple and fast.



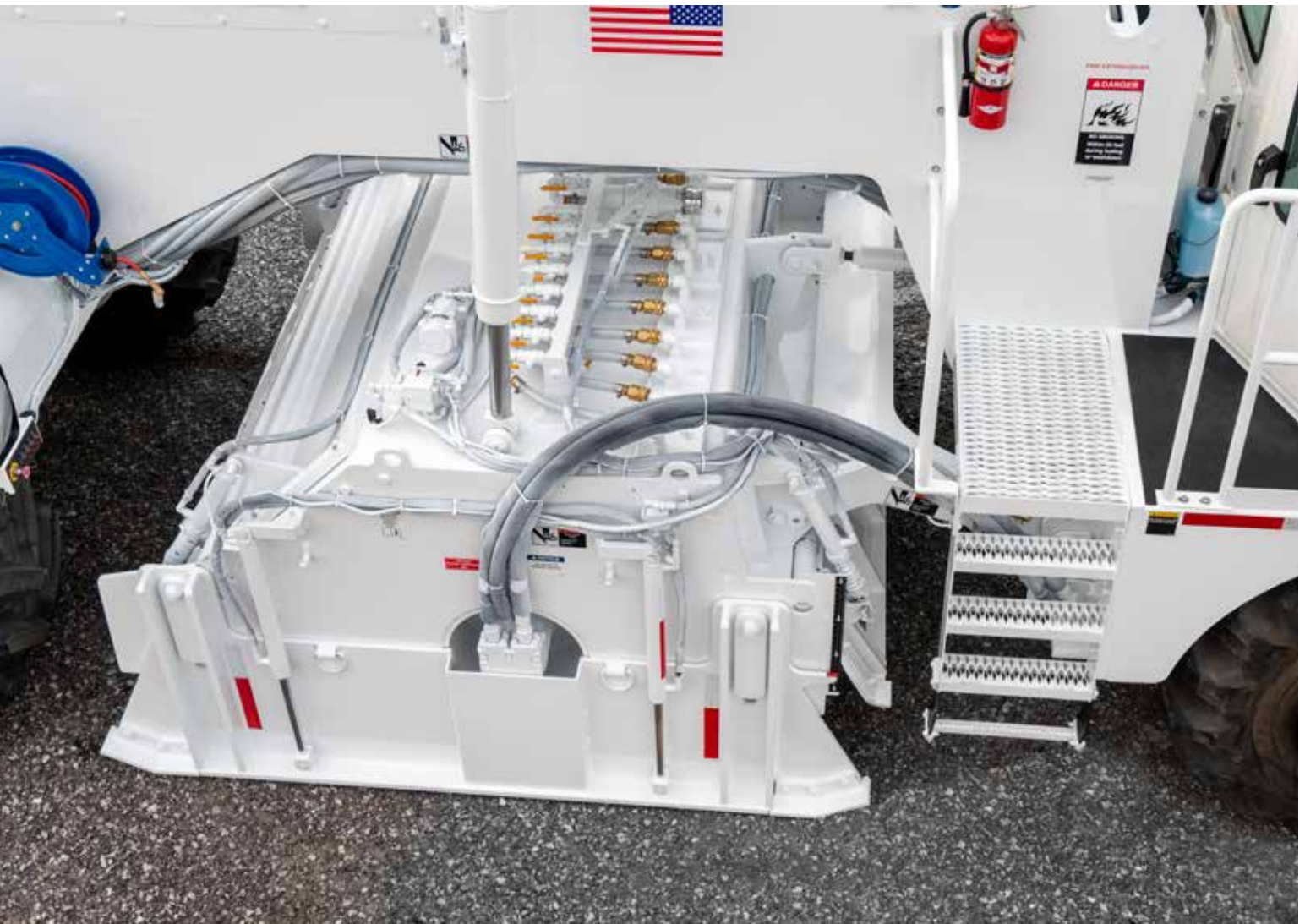

## BEST IN CLASS CUTTER SYSTEM

The SX-5 has a number of different cutter drum designs to suit different applications. Both weld-on tooling and quick-change tooling is available at different tooth spacing. Options include either a quick-change base, which is ideal for reclamation, or a welded base, which is generally used for soil stabilization.

### **Consistent Power with Hydrostatic Drive**

The cutter is driven hydraulically with dual planetary gearboxes, delivering consistent power to the drum.

### **Hydraulic Doors for Easy Access**

Heavy-duty front and rear doors are hydraulically adjustable for additional control of gradation flow, and room behind the drum provides for exceptional mixing and incorporation of additive.

## QX1 QUICK CHANGE CUTTER TOOLING

The sleeve has a longer wear nose for enhanced durability. Notches in the nose allow cutter bits to be removed from the front with a fork tool. Notches in the seating face allow the sleeves to be removed from the front with a small wedge tool.

The Quick Change holder fully seats against the base block for maximum retention and wear resistance. When combined, these features add to the performance and durability of the cutter tooling system.



# PROTECT YOUR INVESTMENT AND KEEP OPERATING COSTS LOW BY MONITORING YOUR MACHINES IN REAL TIME

The Roadtec Guardian® Telematics System is the industry's only live 2-way telematics system. The system consists of software, on-machine viewing screens, and wireless signal boosters to send and receive data. Numerous functions such as engine data and fuel consumption can be viewed at the machine or on your computer screen from a remote location.

Help from Roadtec service is only a phone call away! They see the same information you see and can guide you through the fix or do it for you.

## Monitor & Troubleshoot

- Fuel Consumption
- Engine Codes
- Alarms
- Starting Circuit
- Cutter Circuit
- Auto Water Circuit
- Conveyor Speeds
- Propel Functions
- Load Control
- Steering Circuit
- Machine Production
- Grade & Slope
- Hydraulic Pressure
- Engine Dashboard



## Real-time Machine Data

See everything instantly: from fuel consumption, fault codes, time to service intervals, machine speed, grade and slope settings, or even the exact location of the machine (via GPS).



## Designed by Roadtec for Roadtec

Guardian® Telematics is for Roadtec customers who are looking to dramatically lower operating costs and increase productivity.

## View Remotely and On the Machine

Log into the machine from your computer or you can view the information on the machine's display screens.

## Strong Signal with Cell Booster

The connection to and from the machine is wireless and uses a cell booster to ensure a strong signal. If an Internet connection is unavailable at any given location, the on-board computer stores faults until the connection is restored and then sends the e-mail.

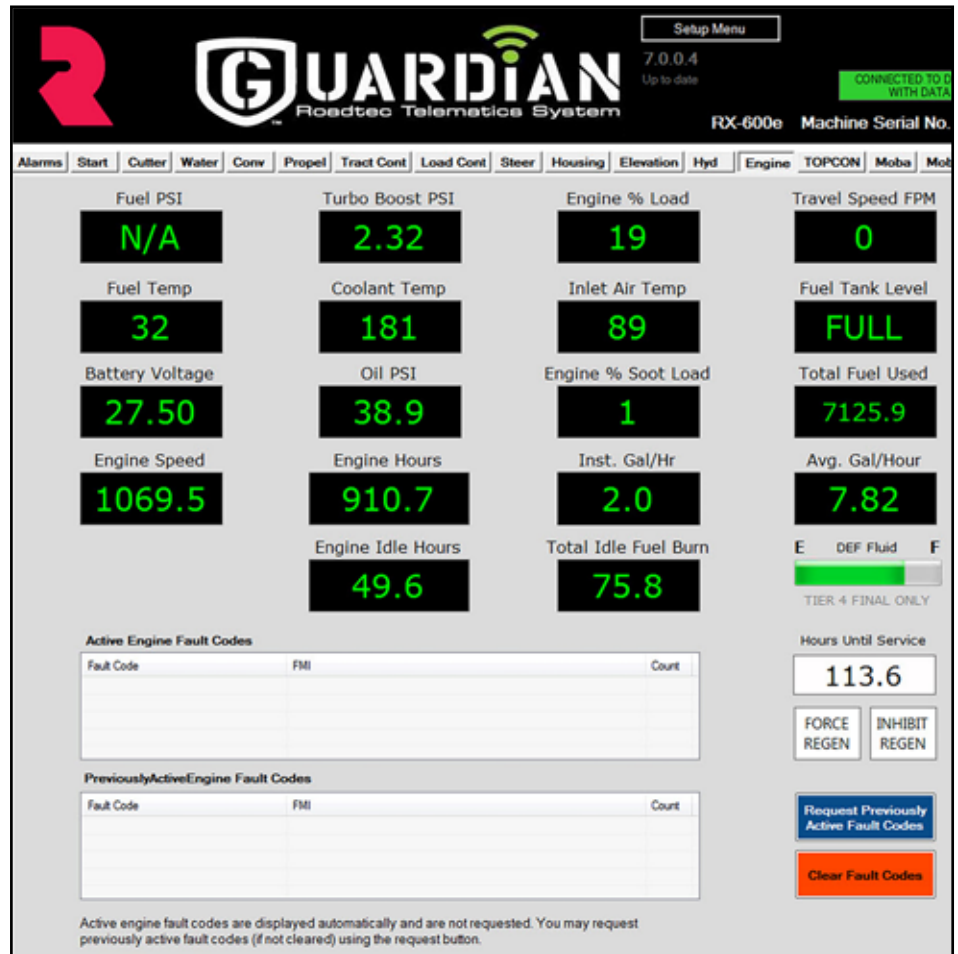

## Your machine can be located by GPS using the Guardian® Roadtec Telematics system.

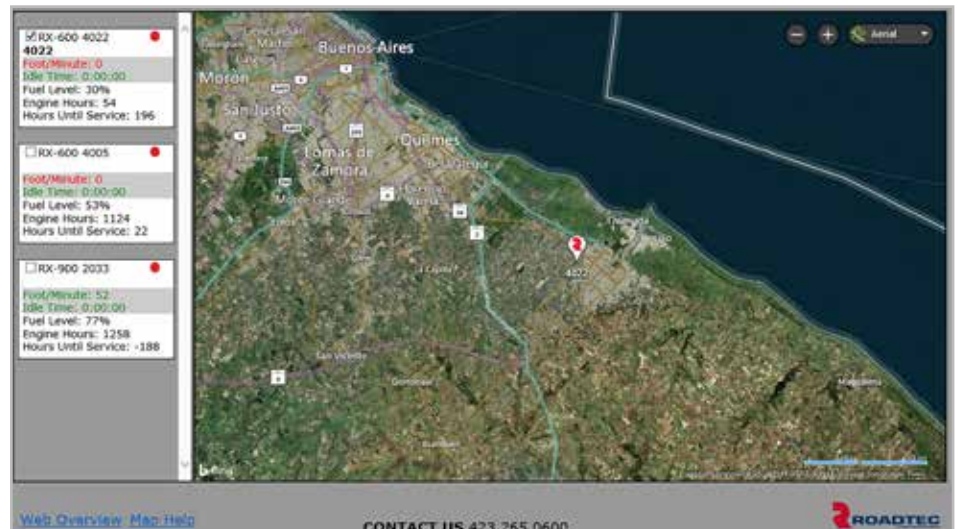

# OPTIONS

## Water & Emulsion Additive System

- 500 gpm (1,893 lpm) capacity with fully automatic controls and manual override

## Tow Hitch

- Rear assembly tow hitch to pull tanker

## 16" (406 mm) Cut Depth

- 50" (1,270 mm) diameter drum required

## Additional Lighting

- (4) 24v high intensity discharge lights

## Additional Cameras

## Drum Spacing (weld-on or quick change tooling)

- 0.737" (18.7 mm) and 1.047" (26.5 mm)

## EDGE® Extended Equipment Warranty

The EDGE® Extended Equipment Warranty is an industry leading warranty that demonstrates Roadtec's confidence in the quality and reliability of our products and our dedication to success. The Edge® warranty goes above and beyond current industry warranties to further protect your equipment investment from unplanned repairs. With Roadtec's extended Edge® warranty, parts and labor are covered for 2 years, and up to 2,000 hours beyond Roadtec's standard warranty period of 1-year/1,000 hours. The EDGE® warranty gives owners a competitive edge by covering most parts at full replacement cost, not including wear components, which lowers operating costs.



# SPECIFICATIONS

## ENGINE

- Tier 4F; Cummins® QSG-12 513 hp (382 kW) @ 1,900 rpm

## WEIGHT

- Shipping weight\*.....59,020 lbs (26,771 kg)  
\* 120 gal fuels & water/injection system

## ELECTRICAL SYSTEM

- CAN-bus serial communication systems for superior performance, reduced wiring, increased reliability & improved service and maintenance features.

## PROPEL SYSTEM

- 4 wheel drive with front and rear propel pumps; diff lock on each axle assembly for max traction

## SPEED

- Travel 6 mph (10 kph)
- Work 266 fpm (57 mpm)

## TIRES

- 23.5-25 L-2 with 3 piece rim, 50 PSI

## STEERING

- Joy stick-controlled. Four steering modes: coordinated steer, crab steer, front steer only, rear steer only.
- Turning radius 23.5' (7.17 m mm) in cut

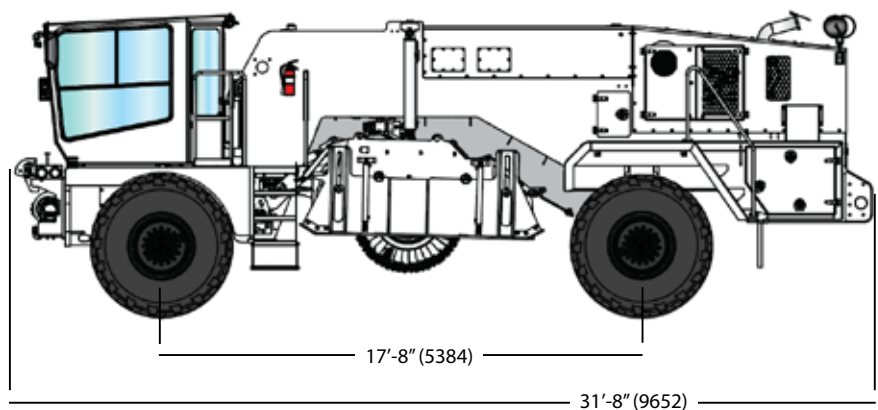
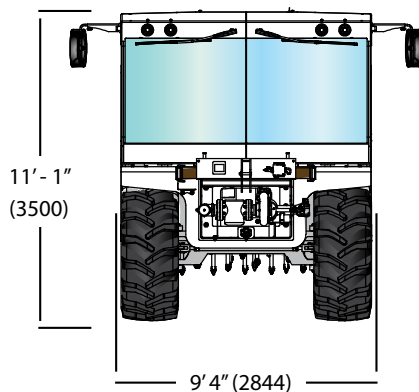

Dimensions in brackets are mm.

Specifications are subject to change without notice.

## OPERATOR STATION

- Fully enclosed and pressurized with A/C and heating system
- Operator Station will shift from left to right side of machine and pivot from the straight ahead position to 90 left or right

## INJECTION SYSTEM

- Water or emulsion
- Up to 500 gpm (1,893 lpm)
- Manual 350 gpm water system

## SERVICE CAPACITIES

- Fuel Tank.....300 gal (1,135 l)
- Hydraulic Fluid Tank ..... 90 gal (340 l)

## CUTTER SYSTEM FEATURES

### CUTTER SYSTEM

- High torque hydrostatic cutter drive
- Dual planetary gearboxes
- 5 selectable drum speeds from operator station

### CUTTER

- 50" (1270) dia x 96" (2438) wide 24" Core for Soil Drum)
- 16" (406) max depth of cut

# ROADTEC.COM

Dedicated to Your Success.<sup>SM</sup>

Roadtec is dedicated to helping you, our industry, and our country succeed.  
Your success builds your business, supports our industry, and strengthens our country.